

1.0 **GENERAL**

1.1 **Related Work and UBC Guidelines**

- .1 Section 12 35 53 Laboratory Casework
- .2 Section 20 00 08 Mechanical Identification for fume hood labelling type
- .3 Section 23 38 00 Fumehood, Lab and Contaminated Exhaust System for fume hood labelling requirements.
- .4 [UBC Resilience-Based Design Guide for Nonstructural Systems](#)

1.2 **Related External Documents**

- 1. Part 30 Laboratories, of the Occupational Health and Safety (OHS) Regulation under the inspection jurisdiction of WorkSafe BC, and the
- 2. Latest edition for CSA-Z- 316.5 Fume Hoods, and Associated Exhaust Systems.
- 3. Canadian Biosafety Standard 3rd Edition, (latest revision), published Public Health Agency of Canada.
- 4. Containment Standards for Veterinary Facilities, Canadian Food Inspection Agency, Publication 1921/E (latest revision).
- 5. Canadian Nuclear Safety Commission Standard GD-52, Design Guidelines for Basic and Intermediate Level Radioisotope Laboratories (latest revision).
- 6. NSF (National Science Facilities) standards (latest revision): for all biosafety cabinets; fully reticulating HEPA filters typical.

1.3 **Description**

- .1 Section includes design and fabrication of fume hoods and bio-safety cabinets.

1.4 **Coordination**

- .1 The Guidelines apply to all work completed within buildings on both UBC Vancouver and UBC Okanagan campuses unless stated otherwise.
- .2 In instances where conflicts are found between these guidelines and provincial regulations or codes, please notify the UBCV Technical Review Team Architect and UBCO Facilities Management.
- .3 These guidelines are intended to be read by design consultants and their content integrated into construction drawings and specifications. Construction documents are not to reference the technical guidelines directly.
- .4 The selection of fume hoods and biological safety cabinets is to be made in consultation with UBC Safety and Risk Services (UBC SRS), UBC Facilities and the principal researcher to ensure that the scientific, safety and engineering concerns are properly addressed.
- .5 Review design intent and additional requirements with UBC SRS. Coordinate with UBC SRS early in the design process.
- .6 Consult with UBC Facilities on requirements to tie fume hoods into existing Building Management Systems (BMS).
- .7 Consult with UBC Facilities on requirements for fume hood modifications in existing buildings and tie-in with existing Building Management Systems (BMS).
- .8 The Coordinating Registered Professional (CRP) is required to coordinate these requirements with other disciplines.

1.5 **Quality Assurance and Submittals**

- .1 Submittals in O&M manual:
 - .1 Manufacturer's data including product specifications.

.2 Maintenance instructions.

.2 Handover/Turn-Over Procedures

.1 Projects are responsible for commissioning and testing all fumehoods and BSC's. Provide a testing and commissioning report for SRS' review.

2.0 **DESIGN AND PERFORMANCE REQUIREMENTS**

2.1 **Design Requirements**

- .1 All fume hoods and exhaust systems shall conform to Part 30 Laboratories, of the Occupational Health and Safety (OHS) Regulation under the inspection jurisdiction of WorkSafeBC, and the latest edition for CSA-Z- 316.5 Fume Hoods, and Associated Exhaust Systems, and show evidence of being performance tested in accordance with ASHRAE 110, Method of Testing Performance of Laboratory Fume Hoods.
- .1 Fume hoods shall conform to the function-specific requirements as applicable in Section 1.2.
- .2 Controls for the operation of the fume hood and service fixtures must be located external to the fume hood, per WorkSafeBC.
- .3 Set the fume hood sash at 15"-18" (381 mm -457 mm).
- .4 The correct maximum operating height of the sash must be clearly marked on the cabinet frame.
- .5 A fume hood must be connected to a local exhaust ventilation system which will provide air velocities over the operational face area of the hood that meet the current WorkSafeBC / OHS Requirements.
- .6 All fumehoods and mechanical sash stops shall be installed with an airflow monitor which complies with WSBC 30.9(5), (6). Any fumehoods within a project's boundaries (i.e. lab renovation) that do not have an existing airflow monitor shall have an airflow monitor installed as part of the project. A recess mounted electronic air monitor shall be mounted on the front face of the hood, indicating high, normal and low air flows, complete with audio and visual alarms.
- .7 Design of building structure to accommodate the provision of shielded radio isotope hoods (UBC to establish which hoods).
- .8 Design and construction must satisfy the containment levels required for foreseeable usage. Whenever a project permits, design and conform to Containment Level 2 requirements to allow flexibility of use even if foreseeable use requires only Containment Level 1.
- .9 Hoods intended for use with Perchloric acid shall be specifically designed for that use and shall be reviewed with UBC Safety & Risk Services and Building Operations, Technical Services. Material that is resistant to Perchloric Acid must be used for the fume hood, duct work, fans and stacks. Stainless steel is not an acceptable material for this service. Wash down systems must extend to the height of the stack.
- .10 Hood baffles are required with top and bottom ventilation slots. These must be fully adjustable and of the same material as the hood liner.

- .11 Fume hoods and biological safety cabinets shall be equipped with a positive lockable latching system. The locking system must allow for the addition of a tradesman's lock that complies with lockout procedures.
- .12 Where provided, the hood accessories must conform to the following specifications:
 - .1 Provide outside controls for all fume hoods as per OHS requirements.
 - .2 Sinks must be integrally welded to the work top or, if epoxy, sealed and recessed into the counter with 38 mm tail pieces.
 - .3 Flush type electrical receptacle consisting of a box 120 volt 15 amp U ground duplex stainless steel face plate must be located on the exterior of the fume hood preferably on the vertical stile.
 - .4 The fume hood must be prewired and CSA approved.
 - .5 The hood must be equipped with a vapor proof lamp and light switch and all wired to a junction box on top of the hood.
- .13 Operable windows are not to be installed in labs in order to allow negative pressures to be maintained relative to adjacent spaces and to prevent draft conditions.
- .14 For new lab buildings with numerous fumehoods, manifolded central systems which meet the requirements of ANSI Z9.5 are generally preferred complete with variable volume hoods, redundant high plume central fans and pressure independent air control valves. In situations with only a few hoods, constant volume hoods with a 1:1 hood to fan ratio may be more economical, simpler and have lower operating costs.
- .15 Seismic restraint requirements to be incorporated in the manufacture of fume hoods and bio-safety cabinets. Restraints and anchorage shall be designed to the BC Building Code. Coordinate with the [UBC Resilience-Based Design Guide for Nonstructural Systems for any requirements above and beyond the BCBC](#).
- .16 UBC Safety and Risk Services to determine additional regulatory and construction standards.

2.2 Performance Standards

- .1 Performance.
 - .1 Life Cycle Costing is to be calculated based on a 15 year life.

2.3 Certification and Commissioning Requirements

- .1 Testing of fume hood airflow performance shall be done by a party approved by UBC. Note that the face velocity requirement is more stringent than WorkSafeBC and that efforts shall be made to ensure that all tests are in the middle of their range. The reason for this is that fume hoods which are passed near the limit of the passing values have been found to be less likely to pass their annual re-certifications for the life of the fume hoods. The test report requires the following results as part of UBC Safety and Risk Services' requirement to approve fume hoods for occupancy:
 - .1 Average face velocity is measured between 0.43-0.57m/s (85-115FPM).

- .2 No single point in the average face velocity is less than 80% of the average face velocity.
 - .3 No single point in the average face velocity is greater than 120% of the average face velocity.
 - .4 **Maximum** cross draft measurements are less than 50% of the average face velocity (as measured 45cm from the face of the sash, using the procedure described in CSA Z316.5).
 - .5 Good smoke containment shown with a smoke test.
- .2 It must be demonstrated to UBC **Facilities** and UBC **Safety and Risk Services** that the fume hoods have been designed and installed to meet all requirements of the UBC Technical Guidelines.

3.0 **MATERIALS**

3.1 **Product Selection**

- .1 Consult with UBC **Facilities**, **Building Operations** for mandatory, approved, or not approved products and materials.
- .2 Fume hoods to be either stainless steel lined or epoxy lined. All fume hood materials must be non-flammable. Radioisotope hoods to be of stainless steel construction.
- .3 Type 316L 16 gauge stainless steel number #4 finish and be of seamless one piece construction with all corners coved and radii.
- .4 All welds ground smooth and polished. A liner must be bolted and cemented to the steel framework forming a rigid and completely sealed chamber.
- .5 The duct stub must be 316L stainless steel.
- .6 The vertical sliding sash must be full view type with 6 mm thick tempered safety glass panel and stainless steel pull, and be counter balanced for smooth operation. Sash shall latch when fully open and when released shall automatically close by gravity.
- .7 For a stainless steel liner, hood work surface must be type 316L 16 gauge stainless steel, seamless welded and integral with liner. The work surface must have 6 mm high marine type edge. The underside of the work surface must have a 20 mm thick plywood sheet bonded to it for rigidity and sound deadening.
- .8 For an epoxy lined hood, the hood work surface must be 20 mm solid black epoxy sealed to the hood liner with a 6 mm high marine type edge sealed to the hood liner.
- .9 Hoods intended for use with radioisotopes to have a reinforced work surface capable of supporting 500 kg.
- .10 Window sash to be equipped with a tempered safety glass.
- .11 Majority of bio-safety cabinets will be Class II Type A2. UBC **Safety and Risk Services (SRS)** to determine if Class II Type B1 or B2 cabinets are required at a meeting between the Consultants and UBC **SRS and end users**.

- .12 As per BCOHS regulation 30.21; an exhaust duct wash-down system shall be part of the design in perchloric acid fume hoods. Wash-down must extend to height of stack and rinsate collected in a reservoir for testing prior to release.

3.2 Finishes

- .1 All fittings or trim in fume hoods to be non-corrosive. Chrome-plated or similar types of 'non-corrosive' finishes are not acceptable.

3.3 Fabrication

- .1 The fume hood must be double walled construction permitting mechanical and electrical service fittings to be mounted on the vertical front stiles.
- .2 Heavy duty galvanized steel framework as well as the service fixture valves and boxes must be housed and concealed within the service chase on both sides of the hood.
- .3 Exterior or interior panels must be independently mounted and easily removable, complete with panels required completing service connections. Exterior service panels are preferred where the installation permits.
- .4 The exterior panels and front stiles must be minimum 1.2 mm powder coated epoxy steel. Air foil must be Type 316L 1.5 mm gauge stainless steel, number 4 finish.

3.4 Service Connection to Biological Safety Cabinets

- .1 Natural Gas
 - .1 Natural gas connections to Biological Safety Cabinets are **not** permitted by the Public Health Agency of Canada (PHAC).
- .2 Water, Drain and Vacuum Services
 - .1 Water, drain, air and vacuum are normally not recommended. In instances where users request any of these services, the Consultant/s to discuss and obtain approval from **UBC SRS**.
- .3 Electrical
 - .1 A duplex outlet is required adjacent to each cabinet supplied from two separate circuits.

2.11 Labelling

- .1 Refer to **UBC Technical Guideline Sections 20 00 08 and 23 38 00**.

*****END OF SECTION*****

1.0 **GENERAL**

1.1 **Related Work and UBC Guidelines**

- .1 Section 12 35 53 Laboratory Casework
- .2 UBC Resilience-Based Design Guide for Nonstructural Systems
- .3 UBC Interior Signage Guidelines

1.2 **Related External Documents**

- 1. National Fire Protection Association (NFPA) Standards.
- 2. Latest edition of the British Columbia Building Code (BCBC).

1.3 **Description**

- 1. Requirements for flammable liquid storage cabinets and corrosives storage cabinets.

1.4 **Coordination**

- 1. The Guidelines apply to all work completed within buildings on both UBC Vancouver and UBC Okanagan campuses unless stated otherwise.
- 2. In instances where conflicts are found between these guidelines and provincial regulations or codes, please notify the UBCV Technical Review Team Architect and UBCO Facilities Management.
- 3. These guidelines are intended to be read by design consultants and their content integrated into construction drawings and specifications. Construction documents are not to reference the technical guidelines directly.
- 4. The Coordinating Registered Professional (CRP) is required to coordinate these requirements with other disciplines.

1.5 **Quality Control and Assurance**

- .1 Submittals
 - .1 Shop drawings.
- .2 Warranties
 - .1 Provide written manufacturer's warranty.

2.0 **DESIGN AND PERFORMANCE REQUIREMENTS**

2.1 **Design Requirements**

- .1 **Flammable Storage Cabinets:**
 - .1 Construct flammable liquid storage cabinets in accordance with the requirements of the B.C. Fire Code. Storage capacity must comply with the B.C. Fire Code.
 - .2 Consult with the UBC Fire Department and UBC Safety and Risk Services for review of the cabinet size and exact location for each installation.
 - .3 Flammable cabinets must not be vented without risk assessment and approval by the chemical safety officer, UBC Safety and Risk Services.
 - .4 Where venting is approved, units must be visibly and durably labelled as vented at time of installation.
- .2 **Corrosive Storage Cabinets:**

The final selection must be approved by the chemical safety officer, UBC Safety and Risk Services.

- ~~.1 Construction to be similar to the requirements for flammable liquids storage cabinets except as noted below.~~
- .2 Corrosive cabinets must not be vented without risk assessment and approval by the chemical safety officer, UBC Safety and Risk Services
- .3 Where venting is approved, units must be visibly and durably labelled as vented at time of installation.

2.2 Performance Requirements

- .1 Seismic restraints and anchorages shall be engineered to the BC Building Code.

3.0 MATERIALS

3.1 Requirements

- .1 Materials:
 - .1 Products **must meet NFPA Standards** (UBC mandatory, approved, or not approved for UBC projects - typ.).
 - .2 Components
 - .1 Flammable Liquid Storage Cabinet
 - .1 **Cabinets must meet NFPA Standards**
 - .2 **Corrosive** Storage Cabinet
 - .1 **Provide certified cabinets.**
 - .2 **Cabinet signage to conform to UBC Interior Signage Guidelines.**
 - .3
 - .3 Finishes
 - .1 Factory finish.

END OF SECTION

1.0 **GENERAL**

1.1 **Related Work and UBC Guidelines**

- .1 Section 03 30 00 Concrete for floor slab loading requirements

1.2 **Description**

1. Section includes special requirements for cranes and hoists.

1.3 **Coordination**

1. The Guidelines apply to all work completed within buildings on both UBC Vancouver and UBC Okanagan campuses unless stated otherwise.
2. In instances where conflicts are found between these guidelines and provincial regulations or codes, please notify the UBCV Technical Review Team Architect and UBCO Facilities Management.
3. These guidelines are intended to be read by design consultants and their content integrated into construction drawings and specifications. Construction documents are not to reference the technical guidelines directly.
4. The Coordinating Registered Professional (CRP) is required to coordinate these requirements with other disciplines.

2.0 **DESIGN AND PERFORMANCE REQUIREMENTS**

2.1 **Design Requirements**

1. Each crane and hoist shall have a separate disconnect switch capable of being locked in the open position. The switch shall be horsepower rated and capable of interrupting the locked rotor current of the crane or hoist motor.

2.2 **Performance Requirements**

1. Equipment design and installation requires full compliance with all applicable regulatory bodies including:
 1. Worksafe BC
 2. CSA B167-96
 3. ASME B30.2-2001

END OF SECTION

1.0 **GENERAL**

1.1 **Related Work and UBC Guidelines**

- .1 Section 07 50 00 Membrane Roofing
- .2 Section 07 55 63 Vegetated Protected Membrane Roofing
- .3 Section 07 61 00 Sheet Metal Roofing
- .4 Section 07 62 00 Sheet Metal Flashing and Trim
- .5 Section 07 72 00 Roof Accessories

1.2 **Related External Documents**

- 1. Latest edition of the British Columbia Building Code (BCBC)
- 2. Province of British Columbia Industrial Health and Safety Regulations pursuant to WorkSafe BC.
- 3. CAN/CSA-Z91-M90 Safety Code for Window Cleaning Operations.

1.3 **Description**

- .1 Section includes design and installation of fall protection systems for UBC maintenance personnel (particularly when parapets are less in height than required for guards), and for window washing equipment and personnel.

1.4 **Coordination**

- 1. The Guidelines apply to all work completed within buildings on both UBC Vancouver and UBC Okanagan campuses unless stated otherwise.
- 2. In instances where conflicts are found between these guidelines and provincial regulations or codes, please notify the UBCV Technical Review Team Architect and UBCO Facilities Management.
- 3. These guidelines are intended to be read by design consultants and their content integrated into construction drawings and specifications. Construction documents are not to reference the technical guidelines directly.
- 4. The Coordinating Registered Professional (CRP) is required to coordinate these requirements with other disciplines.
- 5. All proposed exterior or interior fall arrest or fall restraint systems for new buildings, renewals and roof replacements must be reviewed and signed off by UBC Facilities Building Operations. The UBCV Facilities Technical Review Team Architect or UBCO Facilities Management is to be contacted for assistance with coordination of the review by Building Operations prior to tendering.

1.5 **Submittals and Handover**

- .1 Submittals
 - .1 Shop Drawings
 - .1 Shop drawings to be signed and sealed by a professional engineer registered in the Province of BC and to submit Letter of Assurance ensuring code compliance. Include final reviewed shop drawings and Letter of Assurance in the O&M manual at project completion.
 - .2 Anchor design and load rating drawings shall be provided for each type of anchor in the system.
 - .3 Anchor fastening details must be provided for each type of fastening. The fastener load ratings must be indicated.

- .4 At project completion, submit as-built and record drawings.
- .2 An annual inspection checklist indicating each anchor shall be developed. Every anchor on the roof shall be uniquely identified, and the checklist will correspond to these identifiers. The checklist shall be prepared on 8.5" x 11" sheets. A copy of the checklist will be left in a mounted pouch at the entrance of the fall protection area for review by personnel accessing the fall protection area.
- .3 Provide a comprehensive and detailed description of anchor inspections needed to allow anchors and fastening mechanisms to be inspected by third party personnel. This information is to be included within the O&M manual.
- .4 Provide instructions on the proper use and limitations of the system and testing requirements and frequency.
- .2 Handover/Turn-Over
 - .1 Provide two (2) copies of a reduced plastic laminated record drawing showing anchor locations and detailed fall protection plan clearly depicting the intent and usage of each component and overall system. Copies to be supplied to the UBC Project Manager for posting near roof entrances.
 - .2 Provide drawing(s) indicating the anchoring locations and instructions for use regarding angles and tie off locations. Indicate ground areas requiring pedestrian protection while suspension equipment (bosun's chairs, swing stages etc.) is being used for maintenance, areas over doorways, etc. The drawing shall be printed on a durable medium and mounted at each rooftop access location and fall protection access location inside of buildings.
 - .3 The drawings shall include instructions on any protection requirements for the building parapet walls and/or flashings to ensure that the ropes do not damage the building components and the building components do not damage the ropes.
 - .4 Roof anchor designer/manufacture to provide a comprehensive seminar or demonstration to UBC Facilities Building Operations staff on the components and use of the roof anchor and lifeline anchoring system installation.
 - .5 Window cleaning requirements are to be documented and provided for use by Facilities Custodial Services.
- .3 Quality Assurance
 - .1 Work to be carried out by a company specializing in the type of safety equipment required.
 - .2 All components to be designed and certified by a professional engineer registered in the Province of British Columbia.
 - .3 Roofing penetrations to conform to Roofing Contractors Association of BC (RCABC) standards.
 - .4 Follow manufacturers and roofing inspector's recommendations.
- .4 Quality Control
 - .1 Design structural engineer to carry out site reviews and submit a Letters of Assurance certifying that the anchors meet the performance requirements of CSA Z91M.

- .2 RCABC Inspector to review roof anchor installation to ensure all penetrations are weathertight and detailed to RCABC standards.

2.0 **DESIGN AND PERFORMANCE REQUIREMENTS**

2.1 **Design Requirements for Exterior Fall Arrest or Fall Restraint System**

.1 **Buildings or rooftop surfaces less than 10 feet above grade**

- .1 Fall protection design is not typically required unless the hazard of falling is greater than the hazard of impacting a flat surface. Consideration must be given to what periodic maintenance is required to be performed while on these surfaces to ensure that safe access is achievable using ladders, et.al.

.2 **Buildings or surfaces greater than 10 feet but less than 25 feet above grade**

- .1 A fall protection system design is required for use by [maintenance personnel](#) for the purpose of fall restraint and fall arrest [at this height](#). [Guardrails are the preferred method for fall protection](#). [If guardrails are not used, a variance request will be required for approval](#). Design for window cleaning is only required on buildings where access is not practical from the ground via extension poles or a mobile lift.

.3 **Buildings or surfaces greater than 25 feet above grade**

- .1 A fall protection system design is required for use by [maintenance personnel](#) for the purpose of fall restraint or fall arrest and window cleaning via a bosun's chair [at this height](#). [Guardrails are the preferred method for fall protection](#). [If guardrails are not used, a variance request will be required for approval](#). Attachment mechanisms for swing stage or other roof supported maintenance equipment should only be designed if specifically required for the project; like a high-rise building. A wall stabilization anchoring system is to be provided to prevent the working platform from dangerously swaying in the wind while suspended, where required by code or deemed necessary due to the combination of building accessibility, building height and wind speeds.

.4 **Fall arrest or fall restraint system designs shall include:**

- .1 [Fall arrest or fall restraint system to meet all requirements of the Province of British Columbia Industrial Health and Safety Regulations as per WorkSafe BC regulations.](#)
- .2 [Installation of an exterior monorail system for servicing is not acceptable.](#)
- .3 [All roofing work and roof repair work around roof anchors shall be in accordance with Section 07500 - Membrane Roofing.](#)
- .4 [The fall arrest or fall restraint system shall incorporate the use of rust resistant \(e.g. galvanized metal\), railing anchors, horizontal life lines, signage, etc.](#)
- .5 [Roof anchor design must allow for window cleaning and include safety provisions such as a safety lines for the person \(safety line\) and suspension lines for the suspension equipment \(bosun's chairs, swing stages etc.\).](#)
- .6 [Adhesive and expansion shield anchors are not be used due to load testing inspection requirements.](#)
- .7 [Anchors must be certified that they meet the performance requirements of CSA Z91M.](#)

- .8 Imposed loads on the parapet walls shall be identified on the drawings and the information provided to the [Coordinating Registered Professional \(CRP\)](#) , to ensure that parapets are designed accordingly.
- .9 The *Coordinating Registered Professional* must ensure that rooftop mounted equipment, ducting, skylights, piping, vent stacks, etc. are taken into account and do not impact the operation of the fall restraint or fall arrest system.
- .10 Areas of the roof that are accessible to the general public shall use guardrails that are side-mounted to the parapet or guardrail-height insulated parapets to ensure protection against falls. Coordinate with section 07 00 10 – Building envelope- General Requirements.

2.2 Design Requirements for Interior Fall Protection System

- .1 Installation of an interior monorail system for servicing is not acceptable.
- .2 Special consideration shall be applied to mechanical and electrical equipment including light fixture and sprinkler head installation locations in atriums, common public areas and other unique interior locations that have high ceilings above 10'-0".
- .3 All building equipment and fixtures that require periodic maintenance are to be located in areas that do not require fall protection. If not possible, access should be provided for an appropriately-sized man lift to provide servicing needs of mechanical/electrical equipment, light fixtures and sprinklers located in high ceiling areas.
- .4 Related to item #3 above, the Lighting System Maintainability Plan as per Section 26 51 00, 2.1.8. is to be reviewed with the UBCV Facilities Technical Review Team or UBCO Facilities Management.
- .5 Ensure that floor structure loading, elevator loading plus car dimensions and door heights and widths are adequately-sized to allow a manlift to be brought into the building.
- .6 If manlift access into the building is needed for repair and maintenance activities, lift types and loading diagrams on floor finish types within a project to be reviewed with the UBCV Facilities Technical Review Team or UBCO Facilities Management prior to tender.

2.3 Performance Requirements

- .1 Anchor supplier's structural engineer to design a complete fall protection system to prevent a worker from falling according to WorkSafe BC requirements.

3.0 MATERIALS

3.1 Product Selection

- .1 Cast-in-place material: stainless steel type 304.
- .2 Exposed anchor surfaces and exposed structural components: stainless steel type 304.

END OF SECTION

1.0 **GENERAL**

1.1 **Related Work and UBC Guidelines**

- .1 Section 10 00 10 Special Room requirements – for interior waste room requirements
- .2 UBC Vancouver Solid Waste Infrastructure Guidelines
- .3 UBCV and UBCO Campus Plan
- .4 For hazmat waste storage and pickup requirements, coordinate with UBC Safety and Risk Services

1.2 **Description**

- .1 Section provides information on exterior waste enclosures, waste and recycling infrastructure dimensions, dimensions of waste trucks used on UBC campuses and access route provisions required.

1.3 **Coordination**

1. The Guidelines apply to all work completed within buildings on both UBC Vancouver and UBC Okanagan campuses unless stated otherwise.
2. In instances where conflicts are found between these guidelines and provincial regulations or codes, please notify the UBCV Technical Review Team Architect and UBCO Facilities Management.
3. These guidelines are intended to be read by design consultants and their content integrated into construction drawings and specifications. Construction documents are not to reference the technical guidelines directly.
4. The Coordinating Registered Professional (CRP) is required to coordinate these requirements with other disciplines.
5. Any proposed waste management systems or equipment within the building that differ from the standard equipment types listed in this TG section, or any anticipated need to recycle or dispose any significant amount of “specialty” waste materials that would require additional storage or handling equipment are to be identified for UBC Facilities review. The UBCV Facilities Technical Review Team Architect or UBCO Facilities Management is to be contacted for assistance with coordination of the review by UBC Facilities staff at the design development stage.

2.0 **DESIGN AND PERFORMANCE REQUIREMENTS**

2.1 **Design Requirements**

.1 **Loading Docks / Loading Area**

Building designs need to allow adequate exterior service area space for garbage and recycling containers to be stored and collected or emptied with UBC Facilities waste management vehicles. Containers and vehicles are described in 3.0 below. Minimum requirements for most buildings include:

- .1 Concrete pad for placement of front-load waste containers to prevent long-term surface damage.
- .2 Direct in-line service access to front-load waste containers at least 1.5 times the length of an industry standard front-load compactor truck.

- .3 Outside service area to allow for recycling cart pickup using an industry standard side-load truck which loads from the right side only.
- .4 Ramp or ground level access from the interior waste and recycling storage area to the exterior service area to be provided to allow recycling carts to be wheeled easily to the designated outside pickup area. Refer to Section 10 00 10 for coordination with the interior waste and recycling storage area requirements.
- .5 Service lane widths, turning radii and load bearing capability sufficient to accommodate all waste collection vehicles noted above. Fire truck access standards are typically sufficient and work well for UBC waste trucks.
- .6 Minimum vertical clearance above waste containers to be 23' (feet).

.2 Exterior Waste Enclosures

- .1 3-sided enclosure around concrete pad such that waste bins are visible only from the direction of service vehicle approach. Design to be as per the UBCV/UBCO Campus Plan.
- .2 Minimum access width of 12' (feet) to any front-loading waste container enclosures.
- .3 Refer to the UBC Solid Waste Infrastructure Guidelines, Section 5.1 for additional requirements.

.3 Access Route

- .1 The access route and loading area must be designed in such a way as to allow collection vehicles to enter the site, collect the waste and exit without the need to back up onto a public street.
- .2 Access driveways must be a minimum of 6 meters wide at the point of ingress/egress to the site and a minimum of 4.5 meters wide throughout the site with an unencumbered vertical clearance of 4.4 meters. Consideration should be made regarding width requirements for right or left-hand turns.
- .3 A turnaround area allowing for a three-point turn of not more than one truck length or a drive through access route are acceptable options. The approximate dimensions of the collection vehicle that must be accommodated are presented in paragraph 2.2.
- .4 Turning radii of 9.5 meters inside and 14 meters outside should be available throughout the access route. The slope of the access route shall not exceed 8% and provide adequate vertical clearance throughout the access route.
- .5 Where delivery trucks and waste management trucks have to pass under building overhangs or canopies, provide a minimum of 2' (610mm) clearance above trucks to underside of finished soffit or canopy.

2.2 Performance Requirements (Not Used)

3.0 MATERIALS (EQUIPMENT)

3.1 Waste Containers and Recycling Bins

UBC Municipal Services uses a number of standard waste management containers and utilizes the same types throughout UBC's campuses. Refer to the UBC Solid Waste Infrastructure Guidelines, Section 5.2 for detailed information.

3.2 Typical Recycling, Garbage and Cardboard Collection Vehicles

Standard dimensions of waste collection vehicles are as follows:

Vehicle Type	Size (W x D x H)	Gross Vehicle Weight (kg)
Front-Load Compactor Truck	8.5 x 32.5 x 13.5'	25,000
Roll-Off Container Truck	9.75 x 33.3 x 9.75'	25,000
Side-Load Recycle Truck	9.5 x 31.5 x 12.5'	17,000
Side-Load Truck Extended	12.5 x 31.5 x 16.0'	-

- .1 Typical dimensions for collection trucks used on campus are provided below together with diagrams:

Front Loading Collection Truck

- (approximate) Length 10.0 m - 12.4 m
- Width 3.2 m Minimum inside turning radius 10.0 m
- Minimum outside turning radius 12.8 m
- Height clearance 6.5 m - 7.5 m
- Width clearance 4.0 m
- Length clearance 15.2 m

Side Loading Recycling Truck

- (approximate) Length 10.0 m - 12.4 m
- Width 3.2 m Minimum inside turning radius 10.0 m
- Minimum outside turning radius 12.8 m
- Height clearance 6.5 m - 7.5 m
- Width clearance 4.0 m
- Length clearance 15.2 m

Compactor, Roll-Off Bin and Collection Truck

- (approximate) Length 10.0 m - 12.4 m
- Width 3.2 m Minimum inside turning radius 10.0 m
- Minimum outside turning radius 12.8 m
- Height clearance 6.5 m - 7.5 m
- Width clearance 4.0 m
- Length clearance 15.2 m

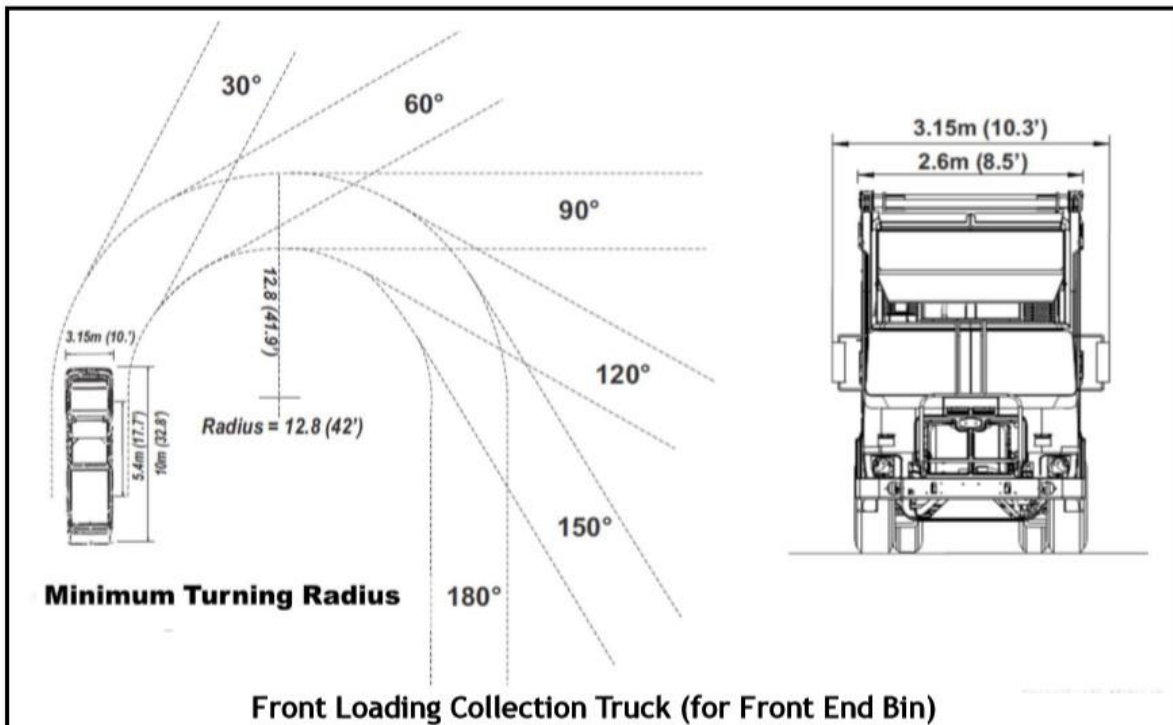
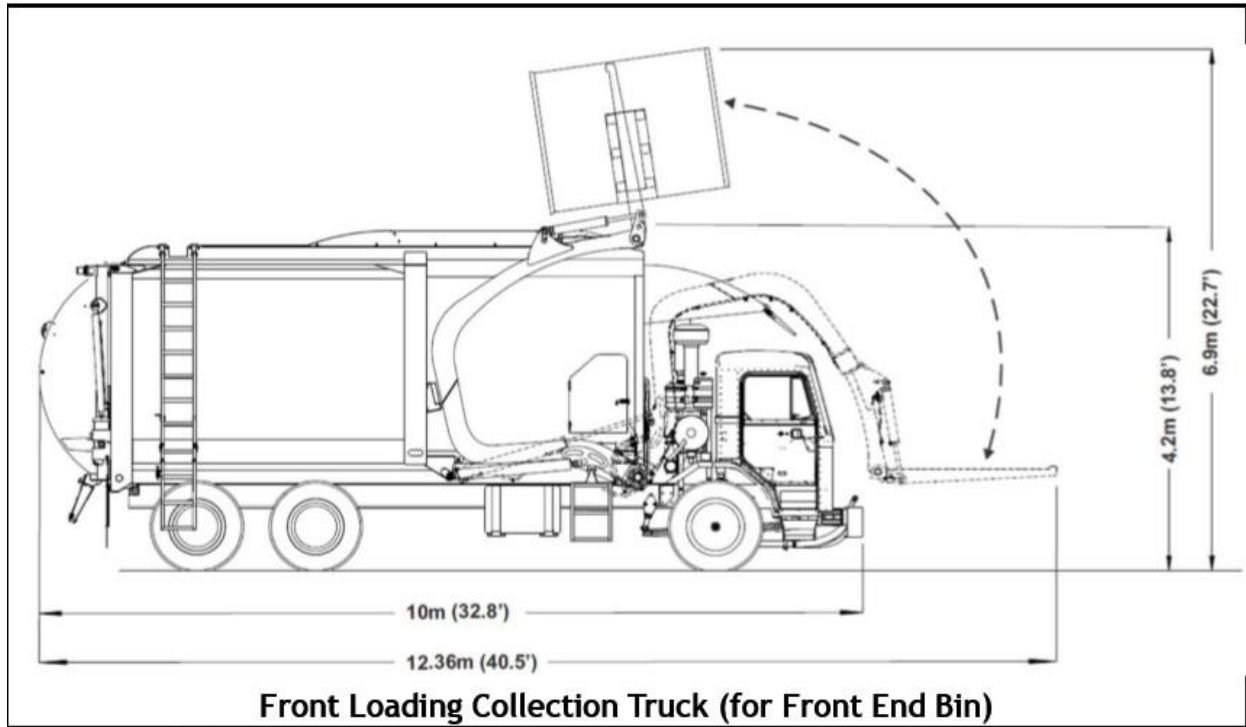



Typical Compactor, roll-off bin and collection truck dimensions

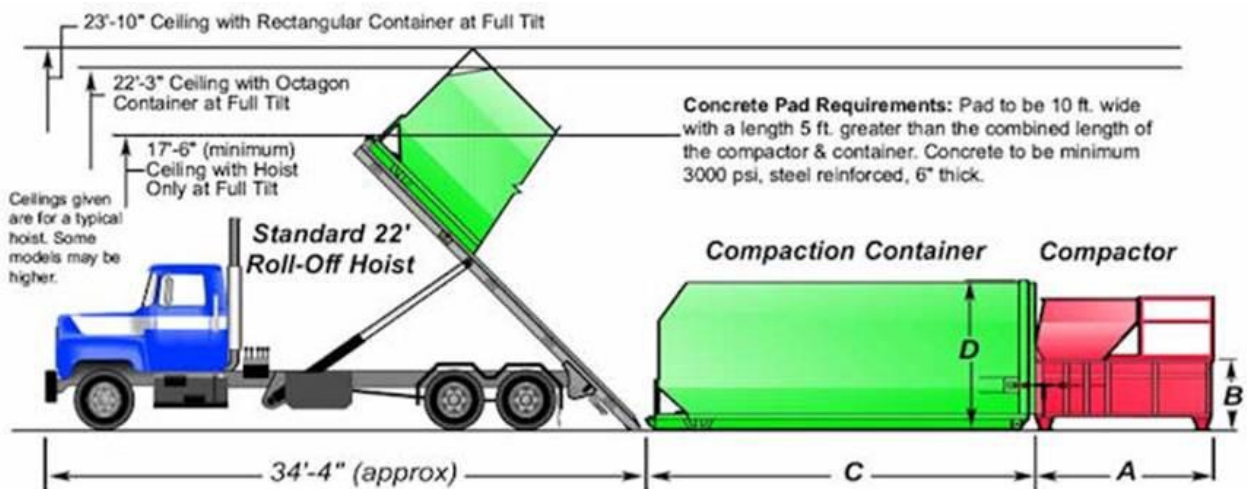



	Left Turn	Right Turn	Tolerance
Wall to Wall Diameter (ft)	90.1	80.3	+/- 3.0
Curb to Curb Diameter (ft)	88.6	78.6	+/- 3.0
Turning Radius (ft)	43.6	38.6	+/- 1.5

END OF SECTION