

1.0 **GENERAL**

1.1 **UBC Energy & Water Services Jurisdiction**

- .1 UBC Energy & Water Services (EWS) is responsible for design, operation, maintenance, and overall stewardship for each of the following underground utility services:
 - .1 Section 33 10 00 Water Utilities
 - .2 Section 33 51 00 Natural Gas Distribution
 - .3 Section 33 63 00 Steam Energy Distribution
 - .4 Section 33 49 00 Storm Drainage
 - .5 Section 33 30 00 Sanitary Sewerage Utilities
 - .6 Section 33 71 00 Electrical Utility Transmission and Distribution
 - .7 Section 33 61 00 District Hot Water Energy Distribution
- .2 The demarcation point of service defining UBC Energy & Water Services' responsibility is included in the respective sections as listed above.

1.2 **UBC Energy & Water Services Contact Information**

- .1 Engineering & Utilities:

6130 Agronomy Rd,
Vancouver, BC V6T 1Z3
Phone: (604) 822-9445
Fax: (604) 822-8833

Energy Conservation & Innovation:
2260 West Mall
Vancouver, BC V6T 1Z4
Phone: (604) 822-5301
- .2 Key Positions in Utilities include:
 - .1 Director, Engineering and Utilities
 - .2 Senior Manager, Electrical Utilities
 - .3 Senior Manager, Mechanical Utilities
 - .4 Mechanical Utilities Engineer
 - .5 Lead Trades: Head Electrician, Head Plumber, Head Steamfitter, Head Utilities Maintenance Engineer.

1.3 **Designer and Contractor Responsibility**

- .1 UBC Technical Guidelines establishes the minimum acceptable standards for the supply and installation of the underground utility services to the buildings on the campus. This is not a design manual. The designer is responsible to ensure that the standards stipulated herein are consistent with the project requirements and are adequate for the project design criteria. The designer shall define the project requirements in the project specification as part of the project tender document.
- .2 Where comments in UBC Technical Guidelines is interpreted to conflict with the industry Standards, Acts and Codes, the compliance with the Standards, Acts and Codes shall prevail and the designer shall bring these conflicts in writing to the attention of the responsible manager at UBC Energy & Water Services.

- .3 The consultant and/or contractor shall provide drawings in accordance with the Technical Guidelines. Within 60 days from backfill, the consultant and/or contractor shall provide a set of Red Line drawings to UBC Energy & Water Services. Upon completion of installation of any new or modified underground utility services and prior to a final walkthrough before hand over to owner, Record drawings of underground utility services shall be provided to *Infrastructure Development, Records*. Record drawings shall show utility service and/or infrastructure details as constructed including, for example, pipe or infrastructure facility size, material, invert and rim elevations, etc. Service profiles shall be provided in congested areas indicating location of all services. See Section 01 78 39 Project Record Documents for details. Upon completion, CCTV inspections must also be provided to UBC Energy & Water Services (see specifications 33 82 01 and 33 01 30.41 at <https://energy.ubc.ca/community-services/contractors-developers/>).
- .4 UBC Energy & Water Services has created checklists intended to guide projects through the steps and procedures required to successfully coordinate with UBC EWS and obtain approval for various construction activities/stages. The forms should be completed and submitted to UBC EWS prior to final completion and acceptance of the project. Note that these forms ONLY addresses coordination with mechanical utilities (water, sanitary, storm and gas) and District Energy. Coordination required for electrical utilities is not outlined in these forms and should be addressed separately. The forms (UBC Mech Construction Checklist and UBC DES Construction Checklist), along with other required connection and activation application forms for contractors and consultants can be downloaded here: <https://energy.ubc.ca/community-services/contractors-developers/>.

2.0 UBC ENERGY & WATER SERVICES (EWS) DEVELOPMENT SUPPORT SERVICES

2.1 General

- .1 Table 2.1.1 outlines the utility requirements assessment in the project approval process for core UBC buildings. Support services and development requirements are defined in terms of UBC Board of Governors approval status.

**Table 2.1.1
 Utility Requirements Assessment
 in the Project Approval Process for Core UBC Buildings**

Timing	Utility Planning and Design Work	Product	Lead Responsibility
Prior to Exec 2	As part of the siting process complete an engineering requirements assessment <ul style="list-style-type: none"> - Run the master servicing model - Complete GIS overlay analysis to identify all utilities requiring move or protection 	Engineering and Services Requirement Document (based on general floorspace)	Campus & Community Planning - May refer to EWS for comment, but always provided for information

Timing	Utility Planning and Design Work	Product	Lead Responsibility
Prior to Exec 3/ Board 1	Utilities Concept Design	Engineering Sketch and Costing* (to be included in project design brief) * to include site plan and possible services connection locations *Project Manager / applicant to provide costing	Campus & Community Planning - Include EWS and project managers in working session to prepare concept design - Variances from Engineering and Services Requirements document must be approved by Managing Director, Building Operations & Associate VP, Campus & Community Planning.
Prior to Board 2	Utilities Schematic Design No later than halfway through the development of schematic design, an integrated design discussion should be held with Campus & Community Planning, EWS and Building Operations representatives	Engineering design drawings* * prepared by applicant team * must be part of Development Permit (DP) Application submission Preliminary service connection application information to be provided	Campus & Community Planning - Design drawings submitted through DP application circulated to EWS and Campus & Community Planning UA/Eng Services for comment in 10 working days - Campus & Community Planning to verify model analysis
Post Board 2	Drawing Review against Technical Guidelines	Service Connection Application with drawings and variance requests from either Engineering Services Requirements document or Technical Guidelines	Technical Guidelines variances approved by Managing Director, Building Operations and Managing Director, Infrastructure Development
Prior to Development Permit Issuance		Development Permit with Engineering Requirements Document attached	Campus & Community Planning for Development Permit

Timing	Utility Planning and Design Work	Product	Lead Responsibility
<p>Engineering Clearance for Building and Streets and Landscape Permits*</p> <p>*Building permits address all onsite engineering works and services; Streets and Landscape permits address all offsite engineering works and services</p>	<p>Vancouver Coastal Health (VCH) Water Connection Permit</p> <p>Review of service connection design for Building Permit and / or Streets and Landscape Permit Applications</p>	<p>Permit from VCH</p> <p>Final Service Connection clearance for either:</p> <p>Staged Building Permit – Excavation / Shoring, Foundation and/ or Full (addresses onsite works and services)</p> <p>or</p> <p>Streets and Landscape Permits (addresses offsite works and services and public realm projects)</p>	<p>Applicants secure permit (or EWS for UBC utility infrastructure projects)</p> <p>EWS to provide Service Connection clearance to Campus & Community Planning</p> <p>EWS to provide Service Connection clearance to Campus & Community Planning</p>
<p>As part of Building Permit process</p>	<p>Site visit prior to backfill of below-grade works and services</p>	<p>Record drawings based on digitized red-line construction drawings, submitted to Infrastructure Development, Records by project manager (set of red line drawings to be provided within 60 days of backfill)</p> <p>Survey of inverts to check compliance with design (completed prior to walk-through)</p> <p>Photos of installation and sewer CCTV inspection reports submitted to Infrastructure Development, Records by project manager</p>	<p>EWS for walk-through of installation and review of red line construction drawings</p> <p>Working Group and Steering Committee for problem solving</p> <p>Final loading data for utilities to be provided by applicant (to Campus & Community Planning and EWS)</p>

2.2 Underground Utility Record Drawings

- .1 Record drawings for all underground utility services must be obtained from Infrastructure Development, Records (Telephone: 604-822-9570).

2.3 Field Inspections

- .1 To verify or complement record drawing information, UBC Energy & Water Services will provide trades staff support to assist in verifying locations, condition, and features of existing underground utility services. Trades staff will be supported by UBC Energy & Water Services engineering and technical professionals.

- .2 Written requests (facsimile or email) shall be submitted as follows:
 - .1 For electrical service contact Senior Manager, Electrical Utilities.
 - .2 For gas, district hot water, water, sanitary, or storm contact Senior Manager, Mechanical Utilities.
- .3 UBC Energy & Water Services charges a \$300 fixed fee per utility service per site. For example, field inspections for water, electrical, sanitary sewer, and storm sewer underground utility services for a new development would cost \$1,200.

2.4 Shutdowns

- .1 UBC Energy & Water Services has sole authority and responsibility to perform shutdowns (or cross connections) of the systems within its jurisdiction. The cost for a service shutdown is based on time and materials, paid by the project.

2.5 Utility Service Connection Permits

- .1 A service connection permit is required for any connection to a utility service as defined in the following Sections in Division 33:
 - .1 Section 33 10 00 Water Utilities
 - .2 Section 33 51 00 Natural Gas Distribution
 - .3 Section 33 63 00 Steam Energy Distribution
 - .4 Section 33 49 00 Storm Drainage
 - .5 Section 33 30 00 Sanitary Sewerage Utilities
 - .6 Section 33 71 00 Electrical Utility Transmission and Distribution
 - .7 Section 33 61 00 District Hot Water Energy Distribution
- .2 The Service Connection Application must be completed and submitted to UBC Energy & Water Services per the instructions on the form. Refer to Energy & Water Services Forms at: <https://energy.ubc.ca/community-services/contractors-developers/>.
- .3 The Service Activation Request must also be submitted to UBC Energy & Water Services prior to any energization of systems. Refer to above link for *Activation* Request form.
- .4 Additional permits from the provincial Electric Safety Branch, Gas Safety Branch, Boiler Safety Branch, Plumbing permits (UBC C&CP) and the Construction Permit from Vancouver Coastal Health, are the responsibility of the project team.

2.6 Development Permit Approval by UBC Energy & Water Services

- .1 The Director, Engineering and Utilities, of UBC Energy & Water Services has sole authority to authorize underground utility service aspects of any development. Sign off of development permits by UBC Energy & Water Services is coordinated by Campus and Community Planning.

END OF SECTION

1.0 **GENERAL**

This section refers to the works that are unique to the requirements for cleaning of new and existing sanitary and storm sewer pipe and pipe culverts.

1.1 **Related Sections**

- .1 Section 33 00 10 Underground Utilities Services
- .2 Regulation - Traffic and Highway Bylaw
- .3 Section 33 82 01 CCTV Pipeline Inspection

1.2 **References**

- .1 This section must be referenced to and interpreted simultaneously with all other sections of the Technical Guidelines pertinent to the works described herein.

1.3 **Material Certification**

- .1 All materials to conform to this specification, to the latest edition of the appropriate specifications of the American Society for Testing and Materials (ASTM) or other standards expressly specified. All provisions in ASTM and other specified standards pertaining to materials, workmanship, finish, inspection and rejection form part of these specifications as far as they are applicable and providing that they are not inconsistent with this specification. This specification takes precedence over the ASTM specifications in case of a discrepancy or conflict. Materials incorporated into the Work but not specifically covered in the specifications are to be obtained from the Contract Administrator prior to installation.

1.4 **Work Regulations**

- .1 Work to conform to all applicable regulations of Work Safe BC Confirm training compliance in the following:
 - .1 Confined space entry procedures
 - .2 Atmospheric monitoring and ventilation methods
 - .3 Personal protective equipment
 - .4 Interpretation of Material Safety Data Sheets (MSDS)

1.5 **Terminology**

- .1 Flushing is defined as a maximum of three (3) passes of high pressure jetting equipment to allow for passage of CCTV or other forms of inspection equipment.
- .2 Cleaning is defined as the removal of all debris by means of high pressure jetting equipment including: gravel, sand, rocks (to 300mm in diameter), grease and other deleterious material.

1.6 **Submissions**

- .1 Submit the following information seven (7) days prior to the commencement of work:
 - .1 Provide schedule and sequence of flushing or cleaning activities
 - .2 Provide dates of training completion for all workers to the Engineer and a list of equipment required for confined space entry.

1.7 **Scheduling**

- .1 Schedule work to minimize interruptions to existing services.
- .2 Hours of work to comply with noise restriction bylaw unless granted exemption.

- .3 Maintain existing flow during sewer cleaning and debris removal unless directed otherwise in contract document.

1.8 Measurement for Payment

- .1 All units of measurement for payment will be as specified herein unless shown in the Form of Tender.
- .2 Sewer cleaning and sewer flushing will be measured in lineal metres. Payment will be made at the unit price bid in Form of Tender.
- .3 Measurement for sewer flushing and debris removal to be determined from plan distances and periodically confirmed by surface measured distances with a calibrated measuring devise.
- .4 Measurement for sewer cleaning and debris removal to be determined from plan distances and periodically confirmed by surface measured distances with a calibrated measuring devise.
- .5 Manhole cleaning will be made at a per unit rate as described in the Form of Tender.
- .6 Root cutting will be measured in hours. Payment will be made at the unit price bid in Form of Tender. Measurement will be determined from the difference in time between when the cutting tool is engaged at the face of the manhole to when it exits on completion of the root removal process.
- .7 Grease cutting and removal will be measured in hours. Payment will be made at the unit price bid in Form of Tender. Measurement will be determined from the difference in time between when the cutting tool is engaged at the face of the manhole to when it exits on completion of the grease removal process.
- .8 Debris disposal is considered incidental to associated cleaning and flushing work. No separate payment will be made for debris disposal.

2.0 PRODUCTS

2.1 Equipment

- .1 High velocity cleaning equipment to be capable of providing a minimum flow of 200 litres per minute (60 GPM) at 140 bar (2000 psi). Cleaning nozzle to be hydraulically or hydro-dynamically propelled and capable of producing a scouring action from 15 to 45 degrees. A variety of ancillary equipment and nozzles to be available including; standard flushing nozzles, high efficiency , spinning jet and plough jet to address all anticipated debris conditions. The equipment to include a water tank, pumps and hydraulically driven hose reel. Equipment to include a wash down gun for cleaning manholes and an approved back flow preventing device for water tank filling.
- .2 Debris removal equipment to consist of a vacuum pump complete with positive displacement pumps or fans producing a minimum of 700 l/s air movement. Equipment to be capable of removing debris at a minimum of 4.5 metres vertical head. Suction hose to be a minimum of 150 mm diameter. Debris tank to be water tight and capable of returning the liquid portion of the debris to the sewer.
- .3 Debris cutting equipment to be an accessory or attachment to hydraulic cleaning equipment. Equipment to be capable of removing heavy roots and solid debris such as encrustation and grease.

- .4 Backflow prevention valves for the purpose of drawing water from hydrants to have air gap and must be pre-approved by the Water Utility Operations Department.
- .5 All water used in the flushing or cleaning of storm sewers shall comply with BC Environmental Management Act and corresponding Municipal Sewage Regulation and be subject to de-chlorination with ascorbic acid or similar approved product prior to use.

3.0 EXECUTION

3.1 Clean or Flush

- .1 Clean or flush all pipelines as specified in contract documents. Notify Engineer immediately in the event that roots, grease or unusual quantities of debris is observed after three passes.
- .2 Notify all affected residences connected to the sanitary sewers in writing of proposed sewer cleaning and CCTV inspection process as specified in the contract documents. Notice to be distributed two (2) working days in advance of flushing. Notice to include Contractor's name and contact information.
- .3 Begin cleaning or flushing from the upstream sewer in the system and proceed downstream. Under no circumstances is the sewer cleaning or flushing process to proceed downstream until all contributing upstream sewers have been cleaned. Sewers to be cleaned or flushed in the direction of flow.
- .4 A manhole to be washed down with high pressure wand AFTER manhole inspection has been completed.
- .5 Remove debris by vacuum pumping at each manhole. Do not pass debris from manhole to manhole.
- .6 Dispose of debris at an approved landfill site
- .7 Comply with applicable Provincial and Municipal environmental laws in regard to the decanting of accumulated waste water with respect to spills and discharge of contaminants.
- .8 Decanting of liquid waste accumulated during debris removal is permitted at a controlled release rate of a maximum of 8 litres per second.

3.2 Water Supply

- .1 Water may be obtained from any UBC fire hydrant once permits are issued. Permit applications will be submitted to Permits & Inspection (Phone: 604 822-8228). Application and instructions are available at <https://planning.ubc.ca/planning-development/permits-and-business-licenses/building-and-trades-permits/trades-permits>
- .2 Dechlorinate all water used for cleaning and flushing storm sewers prior to discharge from tanker in accordance with Section 8 (1) of the Municipal Sewage Regulation.

3.3 Root Removal

- .1 Inform Contract Administrator prior to undertaking any root cutting or grease removal where cutting equipment is required.
- .2 Run root cutter through entire section of pipeline from manhole to manhole or end of pipe to end of pipe.
- .3 Select root cutting devise or grease removal nozzle of appropriately size and configuration for the diameter of the pipeline.

*****END OF SECTION*****

1.0 **GENERAL**

1.1 **System Description**

- .1 The University of British Columbia owns and operates its own water distribution system. The University Endowment Lands (UEL) Administration supplies water to the campus, while the UEL purchases water from Metro Vancouver. Ultimately two pipes feed UBC:
 - .1 24" (600 mm) water main on University Boulevard, which is the suction line supplying the UBC Water Pump Station located south of the Henry Angus Building. The discharge pressure from the pump station is set at 100 psi (689 kPa). This supplies UBC's "High-Pressure Zone."
 - .2 12" (300 mm) water main on 16th Avenue, which supplies UBC's "Low-Pressure Zone." The Low-Pressure Zone is separated from the High-Pressure Zone by seven pressure reducing valve (PRV) stations, one check valve and various normally closed gate valves.

2.0 **MATERIALS AND DESIGN REQUIREMENTS**

2.1 **Responsibilities**

- .1 UBC Energy & Water Services (*EWS*) is primarily responsible for operation, maintenance, and overall stewardship of the water distribution system. Find the Guidelines' website's "Guidelines by Specification Division" link, and refer to Division 33, '*Standard Drawings and/or Detail Documents*' for the demarcation of UBC Energy & Water Services point of service for water supply to buildings, (standard dwg 1140-UT-04-WaterBldgDemarc.dwg). At the same web page, look for information on the demarcation of UBC Energy & Water Services point of service for water supply to irrigation systems, (standard dwg 1140-UT-05-WaterIrrigDemarc.dwg).
- .2 Key positions in UBC Energy & Water Services are described in Division 33, Section 33 00 10 Underground Utilities Services of UBC Technical Guidelines.
- .3 Unless otherwise agreed in writing, the project Designer is responsible for all design, permit, and inspection requirements of the B.C. Plumbing Code.
- .4 The design engineer shall obtain a construction permit from Vancouver Coastal Health for each new installation as well as for any modification of watermains in water transmission or distribution systems, including appurtenances like valves, standpipes or hydrants. These could be watermain projects for the replacement of old pipes, extension, upgrade or looping of the water network, or service connections. For details go to www.vch.ca/your-environment/water-quality/drinking-water/ under 'Water quality resources'.
- .5 The Project Designer must incorporate all specific requirements for Metering, Design and Materials and Execution of this section into the contract drawings in the form of job-specific notes. Only making reference to UBC Technical Guidelines in the drawings is not sufficient.

2.2 **Water Distribution Standards & Policies**

- .1 The latest revisions of the following standards shall apply to water distribution at UBC.
 - .1 UBC Land Use, Permitting and Sustainability Policy - UBC Policy UP12
<https://planning.ubc.ca/planning-development/policies-and-plans/campus-land-use-planning/land-use-permitting-and-sustainability-policy-ubc-policy>

- .2 B.C. Master Municipal Construction Documents (MMCD).
 - .3 B.C. Water & Waste Association (BCWWA).
 - .4 American Water Works Association.
 - .5 CSA Standards (as applicable).
- .2 Where there is a difference between these, Division 33, Section 33 10 00 Water Utilities and the referenced standards, UBC Technical Guidelines shall apply.

2.3 Water Service Connections

- .1 The first step to install new or substantially modified connections to the water distribution system at UBC is to complete a Utility Service Connection Application. This and other forms can be found at <https://energy.ubc.ca/community-services/contractors-developers/>.
- .2 Note that a Plumbing Permit is also normally required by Campus & Community Planning (C&CP) Regulatory Services as the regulatory authority for plumbing requirements of the B.C. Building Code.
- .3 Project design drawings shall provide building load for both peak domestic consumption in litres/second, and fire flow required in litres/second. UBC Energy & Water Services reserves the right to request the calculations used to estimate the peak consumption and fire flows.
- .4 Any new connections to the water distribution system will be reviewed for consistency with UBC Technical Guideline standards. UBC Camps & Community Planning will evaluate the added load using UBC's water distribution model at no cost to the project.
- .5 At the request of the project, a flow test will be performed at the adjacent hydrant to the proposed service connection and the test results are to be provided in writing.
- .6 The Designer shall obtain the Water service records by contacting the Records Clerk at Infrastructure Development, Records (telephone 604-822-9570) and develop proposed service connection location(s). Service connections may be possible to more than one water main fronting the site for large, complex buildings with the approval of UBC Energy & Water Services. For large academic buildings, this is normally required by UBC Energy & Water Services.

2.4 Metering

- .1 Water meters are required for all buildings as per the design requirements shown in the standard drawing 1140-UT-06B-WaterMeterStdMach10. If required, a remote reader shall be installed outside the building in an accessible location. For core campus buildings the design requirements are shown in standard drawing 1140-UT-07A-WaterMeterStdMag. See also Division 26 16 00 Section 2.4.
- .2 All irrigation systems independent of buildings are required to have a meter installed at the service connection. Meter antennas shall be installed on the lid of the irrigation vault or in some other accessible location.
- .3 As indicated on the drawing standards, meters and strainers are to be procured and supplied by UBC Energy & Water Services. The project will provide a purchase order for Energy & Water Services to purchase the meter hardware. There will be no additional markup or procurement fees.
- .4 If the manufacturer and designer confirm that a strainer is not required upstream of a meter, a spool piece with a 1.5"-2" port, isolation valve and hose bib shall be installed in place of the strainer.

2.5 Temporary Water Connections

- .1 Connections to UBC's fire hydrants are allowed with an approved Hydrant Connection Permit issued by Campus & Community Planning (telephone 604-822-2633). Instructions for applying are included in the Fire Hydrant Permit Application. Refer to https://planning.ubc.ca/sites/default/files/2019-11/FORM_UBC_FireHydrantApp.pdf
- .2 A temporary connection to a hydrant is only permitted for a maximum of 30 days. For all other temporary water connections, a Temporary Water Connection Permit for Construction must be obtained from <https://energy.ubc.ca/community-services/contractors-developers/> or call UBC Energy & Water Services (604-822-9445).

2.6 Service Connections and Water Mains

- .1 Water service connections shall be designed per UBC Energy & Water Services standard. Refer to Standard Documents – 1140-UT-03WaterEntry drawing.
- .2 All services should connect to the mainline distribution system at locations within roadways or utility corridors approved by UBC EWS.
- .3 The Project is responsible for permanent capping of un-used stub-outs at the connections to the main lines.
- .4 For Slab on Grade see 1140-UT-08WaterEntrySOG drawing.
- .5 If the building's main water station inside the mechanical room is on the roof, a 1.5 inch hose connection on the combined fire/domestic water service shall be installed at ground level in an accessible location.
- .6 Design consultants shall provide new irrigation service connection tie-in details including chamber location and size, pipe size, material, isolation valve (minimum 2" diameter off main), meter, strainer, backflow preventer and chamber drain connection to the storm system. When a solenoid valve is required to activate water flows, a water hammer arrestor shall be installed upstream of the solenoid valve. Refer to Irrigation Water Supply Vault Standard Drawing 1140-UT-11 for details. Also visit <https://energy.ubc.ca/community-services/contractors-developers/> for the required Irrigation Chamber Service Connection Application form.
- .7 Pipe shall be Class 50 ductile iron pipe manufactured to AWWA C151; cement mortar lined to AWWA C104 and coated 1 mil. thick asphalt.
- .8 Copper, up to 75 mm diameter, type K, joints brazed only.
- .9 Joints shall be single rubber gasket for push-on bell and spigot type joints to AWWA C111, Tyton or approved equal.
- .10 Flanged joints shall be AWWA C110; flat faced conforming to ANSI B16.1, Class 125.
- .11 Fittings shall be ductile to AWWA C110 *or* C153 suitable for pressure rating of 2415 kPa. Cement mortar lined to AWWA C104. Minimum design pressure for piping 1,210 kPa.
- .12 Bolts shall be medium carbon steel or Martensitic steel, ASTM A325 heavy hex finished, hot-dip galvanized to ASTM A153. Coarse threads shall have Class 2A tolerance before galvanizing. Bolt sizes to AWWA110.

- .13 Nuts shall be heavy steel hex carbon steel to ASTM A563 Grade C hot-dip galvanized to ASTM A153.
- .14 Tie rods shall be continuously threaded, quenched and tempered alloyed steel to ASTM A354, Grade BC, hot-dip galvanized to ASTM A153.
- .15 Joint Restraint Devices:
 - .1 All pipe joints are to be restrained with wedge action restrainers meeting AWWA C111 or C153;
 - .2 For pipes 300 mm diameter and larger, boltless restrained joints, meeting AWWA C111 or C153, may be used with EWS approval;
 - .3 All fittings are to be mechanically restrained with wedge action restrainers meeting AWWA C111 or C153.
- .16 Much of UBC's existing water system is not fully restrained. When connecting to the existing system, if it cannot be verified that the pipe is fully restrained, design considerations are required to protect the existing infrastructure from any resultant thrust. Assume all existing pipes are **not** fully restrained unless directed otherwise by a UBC EWS Engineer.
- .17 Thrust blocks are required when impacts to the existing system cannot be eliminated with joint restraints.

2.7 Valves and Valve Boxes

- .1 Gate Valves shall be manufactured to AWWA C509, ductile iron body, resilient seated, non-rising stem, hub or flanged ends.
- .2 Stem seal shall be O-ring type. Valves to be complete with 50 mm square nut for underground operation. Manufacturer shall be Clow or equal approved by **UBC** Energy & Water Services.
- .3 Circular valve boxes shall be Nelson-type as manufactured by Terminal City or Dobney Foundry. Valve box riser pipe to be 150 mm diameter PVC DR35.
- .4 Isolation valves should be installed on each branch of all mainline tees and crosses or as approved by UBC EWS.
- .5 Mainline isolation valves should be located such that each service and hydrant lead can be isolated.
- .6 Maximum distance between isolating distribution valves to be 100 m.
- .7 Maximum depth of valve knuckle or extension rod top to be 600 mm.

2.8 Hydrants

- .1 Fire Hydrants to be 150 mm diameter Terminal City type C-71-P hydrants subjected to hydrostatic pressure test of 2070 kPa in compliance with AWWA C502.
- .2 Maximum hydrant to hydrant spacing is 100 m.
- .3 Minimum size of pipe connection 150 mm.
- .4 Fire hydrant shall have isolating valve not more than 6 m in front of it.
- .5 For hydrant installation requirements see standard dwg. 1140-UT-02FireHydrantDetail.dwg.

2.9 Heavy Equipment Loads on Buried Pipe

- .1 Loads on shallow buried pipe shall be evaluated in the design and construction planning phases. AWWA M41, Section 4.3 can be used as a guide for this evaluation.

3.0 EXECUTION REQUIREMENTS

3.1 Preparation

- .1 All work to follow MMCD Section 33 11 01.

3.2 Trenching

- .1 Trench alignment and depth as shown on Contract Drawings or as approved otherwise by a UBC EWS Engineer.

3.3 Granular Bedding

- .1 Minimum pipe cover to be 1.0 m.
- .2 For pipe bedding use clean granular pipe bedding conforming to MMCD Type 1 Granular Pipe Bedding gradation. Bottom thickness shall be a quarter of pipe diameter, or minimum 100 mm thick. Top shall be minimum 300 mm thick. Sides shall be minimum 225 mm to maximum 300 mm thick.
- .3 Place granular bedding material across full width of trench bottom in uniform layers to 100 mm depth.

3.4 Pipe Installation

- .1 Utility Separation: A minimum 3 m horizontal clearance is required from either sanitary sewer or storm sewer piping, when they run parallel to water main. If this clearance cannot be met, water piping can be installed closer with prior approval from UBC Energy & Water Services. Refer to MMCD Design Guideline Manual Section 1.4, and Vancouver Coastal Health's Water Supply System Construction Permit Guidelines and Application Form (see 2.1.4 this section). Installation may be approved provided water pipe is installed above sanitary or storm sewer piping with minimum vertical clearance 0.5 m and water main joints are wrapped. When crossing sanitary sewers at 90° angle, the water pipe shall be encased with 20 MPa concrete of minimum thickness 150 mm. If concrete is not desirable, joints of the water main can be wrapped with heat shrink plastic or packed with compound and wrapped with petroleum tape in accordance with the latest version of the AWWA Standards C217, and C214 or C209.
- .2 Minimum 750 mm clearance is required from all other services. Minimum 3 m. clearance to building footing or per MMCD General Design guidelines clause 1.3.
- .3 When crossing electric duct bank (crossing shall be done at 90°), run pipe with minimum vertical clearance 150 mm from the bottom of electric duct bank. If crossing of electrical ductbank cannot be done in this manner, then encase water pipe in one larger plastic pipe projecting minimum 500 mm from either side of electric ductbank.
- .4 Test and/or bleed points consisting of Corporation cocks, sized to achieve minimum flushing velocity of 0.8 m/s in accordance with AWW C651, to be provided where shown on Contract Drawings or as required by Utilities Mechanical Engineer for pressure testing and flushing.

- .5 Requirements for piping into the building's mechanical room as per drawing 1140-UT-01WaterStationSchematic.
- .6 Requirements for replacing cast iron or asbestos cement watermains at utility excavations are to be as shown in drawing 1140-UT-09 Water Mains at Excavations. Where water pipes cross under wall foundations, they must be built of ductile iron for a distance of at least 3 metres on either side of the wall, to avoid settlement cracking.
- .7 When excavating over existing A/C or cast iron watermains, only controlled density backfill shall be used. No compaction is permitted.

3.5 Valve Installation

- .1 Valves must be adequately restrained to resist pullout force when closed. Valve restraint systems should include calculated restrained joint lengths on each side of the valve or gravity or dead man thrust blocks or other solutions as approved by UBC EWS.

3.6 Hydrants

- .1 For Hydrants not in service, place an orange painted sign, 30 cm x 30 cm, lettered "Not in Service" on the main port. Remove when water main is accepted by a UBC EWS Engineer.

3.7 Thrust Blocks

- .1 As stated in Section 2.6, thrust blocks are required when joint restraints cannot eliminate thrust impacts to the existing system, or as directed by UBC EWS Engineers.
- .2 Thrust block design considerations must be based on fitting type, water pressure and soil conditions.
- .3 Place concrete thrust blocks between valves, tees, wyes, plugs, caps, bends and undisturbed ground as shown on the Contract Drawings or as directed by a UBC EWS Engineer.
- .4 Thrust blocks to undisturbed soil shall be provided, complete with bearing area and block volume.

3.8 Pipe Surround and Backfill

- .1 Upon completion of pipe laying and before backfilling, Contractor shall notify for inspection UBC Energy & Water Services Head Plumber (604-816-9364). Notification for inspection shall be provided minimum 48 hours in advance.
- .2 After inspection of work in place, surround and cover pipes.
- .3 Trench backfill is to be as per MMCD specifications or as approved by UBC EWS.

3.9 Cleaning and Preliminary Flushing

- .1 Water may be supplied from UBC fire hydrants upon application for a Hydrant Permit.

3.10 Testing and Flushing Procedures

- .1 Contractor shall notify a UBC EWS Engineer and UBC Energy & Water Services Head Plumber 24 hours in advance of testing. (Fax: 604-822-4416). Use the Utility Service

Activation Request form.

- .2 Perform all tests in presence of a UBC EWS Engineer or the UBC Energy & Water Services Head Plumber.
- .3 Testing Procedure & Report as per MMCD Section 33 11 01
- .4 A concise, written and signed report shall be provided to UBC Energy & Water Services.

3.11 Disinfection and Flushing

- .1 Perform disinfection procedure and residual chlorine test in presence of a UBC EWS Engineer or the UBC Energy & Water Services Head Plumber.
- .2 Maintain water chlorinating level (free chlorine concentration mm. 25 mg/L) in new piping for minimum 24 hours.
- .3 Before connection to UBC water system, flush piping clean until maximum free chlorine concentration is less than 0.3 mg/L. Any flushed water must be de-chlorinated.

3.12 Testing New Mains

1. After disinfection and flushing, the new main is filled with potable water and sampled for total coliform and E. coli bacteria (bug test) every 350 m.
2. If a sample fails the test, the main shall be flushed and the sampling repeated. If flushing does not result in an acceptable test, the main should be disinfected again.

3.13 Shutdowns & Connections

- .1 Shutdowns must be requested in writing adhering to UBC's campus-wide standard shutdown procedures. Obtain a Service Shutdown Request form from: <http://buildingoperations.ubc.ca/resources/policies-procedures-forms/> and Utility Service Activation Request form from: <https://energy.ubc.ca/community-services/contractors-developers/>.
- .2 Operating valves on the water distribution system shall only be performed by UBC Energy & Water Services.
- .3 Connections to existing waterworks system may be made by Contractor with approved design, proper notification and UBC EWS approval.
- .4 Notify a UBC EWS Engineer and UBC Energy & Water Services Head Plumber (604-816-9364) with a minimum 24 hours in advance of scheduled connection.
- .5 Make connections in presence of a UBC EWS Engineer or the UBC Energy & Water Services Head Plumber. To prevent damage to existing utilities, excavate the last 300 mm over utility by hand.
- .6 Hot tapping is generally not accepted. If there are exceptional circumstances, hot tapping may be requested in writing, and done only with prior written permission from a UBC EWS Engineer.
- .7 Records of pipe sizes and inverts shall be provided to UBC Facilities, Records; and to *UBC Energy & Water Services*; in accordance with Sections 01 78 39 Project Record Documents and 33 00 10 *Underground Utilities Services* of these guidelines.

3.14 Building Excavation & Shoring Anchors

1. Excavation and shoring anchors shall be located a minimum 1 m clearance to all existing underground utilities.
2. Anchor systems within 3m of finished grade in areas of interest (such as crossing a near-term future worksite) shall be de-tensioned upon completion of work, or as approved by the Director of Energy & Water Services. These anchors of interest shall be identified through the design phase and building permit process with co-ordination from UBC Energy & Water Services, UBC Properties Trust, UBC Facilities including the UBC Facilities Technical Review Team, and others.
3. De-tensioned or removed anchor systems must be certified in writing following completion of work by a Geotechnical Engineer registered with EGBC.
4. Record Drawings must be submitted to Energy & Water Services for any active anchor systems retained tensioned in-place and any de-tensioned anchor systems abandoned in-place following completion of work.
5. Co-ordinate with UBC Technical Guidelines Division 07 (Thermal and Moisture Protection) for waterproofing requirements around de-tensioned anchor systems.

*****END OF SECTION*****

1.0 **GENERAL**

1.1 **Related UBC Guidelines**

- .1 338201s CCTV Pipeline Inspection (see <https://energy.ubc.ca/community-services/contractors-developers/>)
- .2 330130.41s Cleaning of Sewers (link as above)

1.2 **System Description**

- .1 The campus has a dedicated storm drainage system which discharges to the ocean on the north. The south discharges to Booming Ground Creek and to the Fraser River.

2.0 **MATERIALS AND DESIGN REQUIREMENTS**

2.1 **Responsibilities**

- .1 UBC Energy & Water Services (EWS) is primarily responsible for operation, maintenance, and overall stewardship of the storm sewers in cooperation with the following departments/organizations:
 - .1 UBC Health, Safety, & Environment.
 - .2 UBC Sustainability.
 - .3 UBC Properties Trust.
 - .4 UBC Campus and Community Planning.
 - .5 UBC Facilities.
- .2 The demarcation of UBC Energy & Water Services point of service is defined in the standard drawing 1120-UT-01-StormDemarc.dwg found under Division 33 section listings here: http://www.technicalguidelines.ubc.ca/technical/divisional_specs.html.
- .3 The Project Designer must incorporate all specific requirements for design and materials and Execution of this section into the contract drawings in the form of job-specific notes. Only making reference to UBC Technical Guidelines in the drawings is not sufficient.

2.2 **Stormwater Objectives and Standards**

- .1 The latest revisions of the following standards shall apply to storm sewers at UBC.
 - .1 B.C. Master Municipal Construction Documents (MMCD).
 - .2 Metro Vancouver's Sewer Use Bylaw latest edition.
 - .3 UBC Environmental Protection Policy #6 (<http://universitycounsel.ubc.ca/policies/index/>).
 - .4 UBC Sustainability Development Policy #5 (<http://universitycounsel.ubc.ca/policies/index/>).
 - .5 Fisheries Act.
 - .6 BC Ministry of Health.
 - .7 UBC's Integrated Storm-water Management Plan (ISMP).
- .2 The following guidelines should be considered in design and construction of stormwater systems:

- .1 Best Management Practices (BMP) Guide for Stormwater, Greater Vancouver Sewerage and Drainage District Liquid Waste Management Plan. Search the <http://www.metrovancouver.org> website.

2.3 Storm Sewer Connections

- .1 The first step to install any new or substantially modify connections to the storm sewer system at UBC is to complete a Utility Service Connection Application. This and other forms can be found at <https://energy.ubc.ca/community-services/contractors-developers/>.
- .2 Campus Planning and Development's Regulatory Services also require a Plumbing Permit to meet provisions of the B.C. Building Code Plumbing Provisions.
- .3 Any new connections to the storm sewer system will be reviewed for consistency with the Storm Drainage Master Servicing Plan, and if necessary the stormwater engineering model will be updated and run by UBC Energy & Water Services at no cost to the project.
- .4 The Designer shall obtain the Storm service records by contacting the Records Clerk at Infrastructure Development, Records, and develop proposed service connection location(s).
- .5 Service connections may be possible to more than one storm sewer main fronting the site.

2.4 Stormwater Management Plan

- .1 As part of the site design submission, a Stormwater *Management* Plan is required if one of the following conditions is met:
 - .1 The development site is 0.5 hectares (5,000 m²) or more.
 - .2 The development involves one or more new buildings.
 - .3 Net increase in stormwater runoff is 50 l/s or more based on 10 year return period and 10 minute duration storm (use Environment Canada's latest IDF curve for YVR/Vancouver International Airport found at https://climate.weather.gc.ca/prods_servs/engineering_e.html).
 - .4 There are features of the development which could lead to stormwater quality problems such as parking facilities.
- .2 If a Stormwater Management Plan is required, the Designer shall provide a written document which clearly summarizes:
 - .1 The storm flow design computations which shall include, but not necessarily be limited to, a figure indicating the catchment area and land use condition, along with a list of all design parameters and resulting design flows for the storm system. The design flows and hydraulic grade line must be indicated for all pipe reaches.
 - .2 Description of potential stormwater contaminants and how stormwater quality will be controlled.
- .3 The Stormwater Management Plan need not be a large document, and the effort should be in proportion to the size and complexity of the development. For example, a single building development may adequately summarize stormwater design in one or two pages.
- .4 A copy of the Stormwater Management Plan shall be provided to the following:
 - .1 Green Infrastructure Engineer – Campus & Community Planning (Fax: 604-822-6119).
 - .2 Manager, Mechanical Utilities - UBC Energy & Water Services (Fax: 604-822-8833).

- .3 Director, Sustainability - UBC Land & Building Services (Fax: 604-822-6119).
 - .4 Manager - UBC Health, Safety, & Environment (Fax: 604-822-6650).
 - .5 Landscape Architect Planner - Campus & Community Planning (Fax: 604-822-6119).
 - .6 Landscape Architect – UBC Facilities (Phone: 604 822-7913).
- .5 The storm water management plan must be discussed with and approved by the UBC Green Infrastructure Engineer and UBC Energy and Water Services.
- .6 Approval of the Stormwater Management Plan is confirmed with authorization of the Development Permit.

2.5 Storm Sewer Design

- .1 Control of stormwater quality shall be addressed in the Stormwater Management Plan. Best Management Practices (BMP's) shall be implemented to protect stormwater runoff quality. A reference document for applicable BMP's is Metro Vancouver's Best Management Practices Guide for Stormwater. This document should also be consulted for associated design information.
- .2 The Designer is encouraged to incorporate methods of biofiltration into the site design to assist with water quality treatment. This includes such features as grassed swales, vegetated buffer strips, french drains, engineered wetlands, etc. Engineered BMP's described above may be reduced or eliminated if adequate biofiltration measures are incorporated into the site design. If biofiltration is proposed for a development, it shall be included in the Stormwater Management Plan.
- .3 The Rational Method shall be applied for the design of all drainage systems servicing an area of 1 hectare or less. The hydrograph method shall be used for catchment areas exceeding 1 hectare. Hydrograph modeling shall also be applied where stormwater detention facilities are incorporated into the storm system. All hydrograph modeling shall be completed using either Visual OTTHYMO or a SWMM based program compatible with XP-SWMM2000.
- .4 The storm service system shall be designed within the project site and to the receiving trunk sewer to convey the peak 1:10 year return period storm flows. The storm duration that results in the highest peak flow should be used for design. In most cases, the sewer system shall be sized to ensure that the maximum hydraulic grade line elevation remains within the pipe. Under unique circumstances, surcharging below ground surface may be permitted provided it can be demonstrated that no risk to buildings or property result.
- .5 Rainfall intensity-duration-frequency (IDF) curves and associated rainfall data for all storm flow calculations are to be based off Environment Canada's latest IDF curve for YVR/Vancouver International Airport (found at https://climate.weather.gc.ca/prods_servs/engineering_e.html).
- .6 The Designer shall select a time of concentration (T_c) and run-off coefficient (R) which are appropriate for the proposed development. The " T_c " shall be the sum of the inlet time and travel time. In most cases, the inlet time shall be 10 minutes when the impervious surface flow path length to the storm inlets is 100 meters or less.
- .7 Storm water shall flow only by gravity into the UBC storm system. Only under unique circumstances will pumped storm water be considered. Perimeter drains can be pumped into the UBC storm system, but a request for a permission to do so shall be submitted to UBC Energy & Water Services with an explanation why the storm water cannot be discharged by gravity, the proposed pump capacity (L/s) at operating head (kPa), a diagram showing pump

- curve with superimposed piping system curve at operating flow and head and sump dimensions with elevations at which pump starts and stops. Sump volume between pump start and stop elevations shall be sized so that the maximum number of On/Off cycles does not exceed six per hour.
- .8 When extending the existing trunk lines, sufficient size, depth and slope of the sewer shall be maintained to facilitate the future extension of service in accordance with the Storm Drainage Master Servicing Plan.
 - .9 All storm sewer piping shall be designed with a minimum velocity of 0.6 m/s when flowing full or half full, based on the Manning's formula. Special provisions must be provided for supercritical flow or where the velocity exceeds 3.0 m/s to ensure structural stability and durability concerns are addressed.
 - .10 The minimum slope shall be 1.0% for CB leads, 0.2% for storm mains smaller than 600 mm in diameter, and 0.1% for storm mains 600 mm in diameter and larger.
 - .11 All catch basins, lawn drains and other inlet structures shall provide a sump and trash hood in accordance with MMCD standard drawings.
 - .12 An American Petroleum Institute (API) Oil Water Separator or equivalent product such as Lafarge's Stormceptor chamber shall be incorporated at the most downstream point of the on-site storm drainage system for all parking facilities providing 20 or more parking stalls. The system shall be appropriately sized and include a bypass to reduce flushing of contaminants during elevated flows.
 - .13 For underground parkades, drains should not be connected to the storm drainage system but rather to a 'Parkade Drainage Treatment System' (PDTs) and then discharge to the building sanitary sewer system. UBC has adopted the standards of the City of Vancouver's Bulletin 2008-007-EV/PL, latest revision.
 - .14 Manholes at maximum 100 m spacing shall be installed at each branch connection and each change of direction. Top of manholes shall be 150 mm above the ground in all landscaped areas, otherwise flush with surface. Pipe shall be straight between manholes.
 - .15 A minimum pipe size of 200 mm shall be used for gravity service mains in residential areas and 250mm in research/industrial areas. Service connections with a minimum pipe size of 150mm may be used with written approval from UBC EWS.
 - .16 MMCD inspection chambers are not allowed on the storm sewer systems under UBC Energy & Water Services jurisdiction.
 - .17 The downstream sewer pipe shall be equal or larger diameter. However, an exemption may be obtained with UBC Energy & Water Services' approval. For storm drainage hydraulic details, refer to Section 4.0 for the MMCD Design Guideline manual.
 - .18 Where drop manholes are required, drops shall be outside, with clean-outs. For standard details refer to MMCD manhole installation standards.
 - .19 Catch basins shall be spaced to service a maximum area of 500 m² on grades up to 3%. For grades exceeding 3% the spacing shall be reduced to an area of 350 m². Special consideration shall be given at low spots to ensure that adequate capacity is provided. A minimum pipe size of 150 mm shall be used for CB leads.

- .20 The maximum service length, between the building face and the first storm sewer connecting manhole, shall be 75 m. Service connections less than 20m length shall connect to sanitary mains as per MMCD Section 33 03 01 or as approved by UBC EWS.
- .21 All services should connect to the mainline distribution system at locations within roadways or utility corridors approved by UBC EWS.
- .22 A minimum 750 mm, pipe wall to pipe wall, horizontal clearance is required where the storm sewer is installed within a common trench with the sanitary sewer. If the invert of the sanitary sewer varies significantly from the storm sewer, the Designer shall give special consideration to the horizontal spacing. Clearance from building footings shall be approved by EWS and be a minimum of 3 m per MMCD General Design guideline clause 1.3.
- .23 When crossing electric duct bank, run pipe below electrical duct bank with minimum 150 mm vertical clearance from the bottom of electric duct bank. Crossing angle shall be between 45° and 90°.
- .24 Provide positive slopes away from entrances and exits (not less than 4%) to adequate storm drains or gratings that will allow a ponding depth of at least 100 mm. (This will, in normal cases, give sufficient lead time to remedy flooding situations before interior floor finishes are damaged). Install continuous gratings in lieu of catch basins and drains where broad sheets of water are anticipated to flow down pathways and roads towards entrances. Where possible provide alternate means for water to escape if a drain is plugged such as overflow scuppers, secondary French drains, etc.
- .25 All regional-level drainage detention facilities shall be designed as per UBC's Integrated Rainwater/Stormwater Management Plan, or as approved by the Director of Sustainability & Engineering and the Director of Energy & Water Services. A detention facility is considered regional-level detention storage if:
 - .1 It is located downstream of any storm sewer main as indicated in the UBC Standard Drawings Division 33 Utilities - 1120-UT-01 Storm Demarcation drawing; and
 - .2 It is identified as such in the UBC Integrated Rainwater/Stormwater Management Plan.
- .26 An oversized pipe may be used for building-level drainage detention, but is not permitted for regional-level detention storage unless approved by the Director of Sustainability & Engineering and the Director of Energy & Water Services. An oversized pipe is considered a detention facility if it includes a device or feature designed to control the discharge from the pipe. Maintenance access for an oversized pipe detention facility is required at the inlet, outlet, and at all pipe connections into the detention pipe.

2.6 Materials

- .1 Unless otherwise approved by UBC Energy & Water Services only the following pipe material shall be used for the gravity storm sewer system:
 - .1 PVC, class SDR 28 (required for 150 mm diam. and smaller) and SDR 35.
 - .2 Concrete (reinforced C76 required for all pipes 600 mm in diameter and larger).
 - .3 Corrugated HDPE having a minimum pipe stiffness of 320 kPa may be permitted under unique circumstances.
 - .4 PVC piping is preferred for all piping 300 mm in diameter or smaller.

3.0 **EXECUTION REQUIREMENTS**

- .1 Storm sewer works and appurtenances shall be installed in accordance with the current MMCD standards and specification, unless otherwise noted.
- .2 Minimum cover on all storm sewers shall be 1.0 meters in accordance with the MMCD standards. Where no future main line extension or connection of services, lawndrains, or catch basins is required, and where no traffic road exists or in future will exist, minimum cover may be reduced to 600 mm with special approval.
- .3 Site grading and surface inlets shall be located to ensure that stormwater is contained and controlled within the boundaries of the site.
- .4 Washout from concrete trucks and spray washing of exposed aggregate pavement shall conform to Metro Vancouver's Best Management Practices for Stormwater Guide (Appendix H Construction Site Erosion and Sediment Control Guide) BMP CP10.
- .5 All pipe surround material shall consist of clean granular MMCD Type 1 bedding.
- .6 Trench backfill is to be as per MMCD specifications or as approved by UBC EWS.
- .7 For purposes of cleaning and flushing, water may be supplied from UBC fire hydrants upon application for a Hydrant Use Permit. Refer to <https://planning.ubc.ca/planning-development/permits-and-business-licenses/building-and-trades-permits/trades-permits>.
- .8 As per Energy & Water Services' supplementals (see item 1.1), UBC Technical Guidelines Sections 33 82 01 and 33 01 30.41. A concise, written and signed report and video inspection shall be provided to UBC Energy & Water Services.
- .9 Prior to covering the pipe, all installed and bedded pipe shall be inspected by *UBC Energy & Water Services*. The Contractor shall provide written notification to a UBC EWS Engineer and the EWS Head Plumber with minimum of 24 hours notice.
- .10 Records of pipe sizes and inverts shall be provided to the Records Manager, Infrastructure Development (Phone: 604-822-7217); and also to the UBC Energy & Water Services, in accordance with Sections 01 78 39 Project Record Documents *and* 33 00 10 *Underground Utilities Services* of these guidelines.
- .11 Where notification requirements are not met, services may need to be re-excavated for inspection and/or testing upon request of UBC Energy & Water Services.

END OF SECTION

1.0 **GENERAL**

1.1 **System Description**

- .1 The University of British Columbia owns and operates its own natural gas distribution system. All parts of the system are non-interruptible (firm gas) service, except the supply to the steam plant.
- .2 There are three pressure zones within North Campus part of the system (north of 16th Avenue) as follows:
 - .1 1.8 kPa (7" water) low pressure.
 - .2 34 kPa (5 psig) medium pressure.
 - .3 83 kPa (15 psig) high pressure.
 - .4 414 kPa (60 psig) high pressure.
 - .5 The UBC Okanagan campus operates low and medium pressure zones.
- .3 The south campus (south of 16th Avenue) operates at 83 kPa (12 psig).
- .4 Steel gas piping system throughout UBC Campus has a complete cathodic protection system.

2.0 **MATERIALS AND DESIGN REQUIREMENTS**

2.1 **Responsibilities**

- .1 UBC Energy & Water Services (EWS) is primarily responsible for operation, maintenance, and overall stewardship of the natural gas distribution system. The demarcation of UBC Energy & Water Services point of service is as shown on Gas Meter standard drawing found under Division 33 section listings here:
http://www.technicalguidelines.ubc.ca/technical/divisional_specs.html.
- .2 Where there is no gas meter for a given building, UBC Energy & Water Services demarcation point is the last valve outside the building wall.
- .3 UBC Energy & Water Services is not responsible for any part of the gas piping or equipment inside buildings.
- .4 For all natural gas pipeline and service projects, the Project Designer must incorporate all specific requirements for metering, design and materials and execution of this section into the contract drawings in the form of job-specific notes. Only making reference to UBC Technical Guidelines in the drawings is not sufficient.

2.2 **Natural Gas Distribution Standards**

- .1 The latest revisions of the following standards shall apply to natural gas distribution at UBC:
 - .1 UBC Sustainability Development Policy #5
(<http://universitycounsel.ubc.ca/policies/index/>).
 - .2 B.C. Gas Safety Act.
 - .3 Canadian National Gas Code.
 - .4 National Association of Corrosion Engineers (NACE)
 - .5 CGA Standard (as applicable).
 - .6 CSA Standard (as applicable).

2.3 Natural Gas Service Connections

- .1 The first step to install any new or substantially modified connections to the natural gas distribution system at UBC is to complete a Utility Service Connection Application. This and other forms can be found at <https://energy.ubc.ca/community-services/contractors-developers/>.
- .2 Any new connections to the gas distribution system will be reviewed for consistency with UBC Energy & Water Services standards.
- .3 Project design drawings shall provide building load (list of appliances with nameplate capacities in m³/hour) and required pressure.
- .4 The Designer shall obtain the gas service records by contacting the Records Clerk at Infrastructure Development, Records, and develop proposed service connection location(s). Service connections may be possible to more than one gas main fronting the site.

2.4 Metering

- .1 Natural gas meters are required for all buildings. All meters shall be temperature compensated. Gas meter design requirements are as shown in Standard Documents - GasMeterStd.dwg, the location of which is referenced in section 2.1.1 above. Revenue gas meters shall have reading in m³, shall be provided with PFM regulator, ISO 9001 (smaller meters) or with electronically compensated pressure and temperature (larger meters).
- .2 The mean atmospheric pressure for PFM (Pressure Factor Measurement) is 100.71 kPa for all revenue natural gas meters on UBC Campus.
- .3 As indicated on the drawing standard, the meter assembly is to be procured and supplied by UBC Energy & Water Services at the project's expense. The project will provide a purchase order for Energy & Water Services to purchase the meter hardware. There will be no additional markup or procurement fees.
- .4 The project is responsible for providing any required protection, such as installing a lockable enclosure and/or bollards as per UBC Energy & Water Services approval.

2.5 Seismic Protection

- .1 The decision whether to install seismic shutoff valves is the responsibility of the project consultants. Buildings which meet the following criteria may not benefit significantly by installing a seismic shutoff valve:
 - .1 Building is structurally designed for current seismic codes.
 - .2 Restraints installed on all gas equipment (e.g. water heaters, air heating units) and piping.
 - .3 Flexible connections installed on all gas equipment.
- .2 Buildings which use natural gas for emergency power or other emergency needs are recommended not to install seismic valves.
- .3 When installed, the following valves are required: California Seismic™ (formerly Koso™) valves for horizontal orientation: Safe-T-Quake valves for vertical orientation. Seismic gas valve shall be supported with two (2) brackets secured to a building wall or equivalent.
- .4 Regardless, UBC Energy & Water Services requires that seismic restraints be used on all gas equipment (i.e. water heaters) and main gas piping in the building.

- .5 UBC Energy & Water Services requires that flexible gas connections be used on all gas equipment in the building.

2.6 Design and Materials

- .1 Design piping pressure: 415 kPa (60 psig).
- .2 Connections shall be to the highest available pressure.
- .3 New underground piping shall be SDR11 Series 125 Polyethylene, manufactured to CAN 3-B137.4M86. New underground valves shall be PSV polyethylene shut off valves with butt fusion outlet ends, to accommodate SDR 11 pipe, conforming to ASTM D-2513. Pipe fittings shall be butt heat fusion polyethylene manufactured to ASTM D-3261-85.
- .4 New aboveground piping up to shall be minimum Schedule 40, ASTM A53 steel piping. Up to, but not including the gas meter assembly, all piping shall be painted yellow. All piping up to 2" size shall be socket welded, manufactured to ASTM A182. New piping over 2" may be butt welded. All aboveground valves shall be bronze plug-type shutoff valves with threaded outlet ends to accommodate A53 steel pipe, and conforming to ASTM B62.

2.7 Permits

- .1 Permits by B.C. Gas Safety Branch and inspections/witness by B.C. Gas Safety Inspector of pressure testing and purging are the sole responsibility of the project.

2.8 Notification

- .1 The Mechanical Utilities Engineer (Telephone: 604-822-3274) and Utilities Head Plumber (Telephone: 604-822-5986) shall be notified in writing 24 hours in advance of any planned pressure testing of a new gas service pipe. Failure to provide notice may result in installed services to be re-excavated for inspection.

3.0 EXECUTION REQUIREMENTS

- .1 Minimum soil cover shall be 600 mm.
- .2 Warning tape at 300 mm below grade level shall be provided.
- .3 Minimum 1.0 m wall to wall horizontal clearance is required from all other services. Clearance from building footings shall be approved by EWS and be a minimum of 3 m per MMCD General Design guideline clause 1.3.
- .4 When crossing electric ductbank, run pipe above electrical ductbank with minimum vertical clearance 150 mm from the top of electric ductbank. Crossing angle shall be 90° degree. If crossing of electric ductbank cannot be done in this manner, then encase natural gas pipe in one larger plastic pipe projecting minimum 500 mm from either side of the electric ductbank.
- .5 Contractor shall provide and install a top tracer wire attached to underground polyethylene pipe.
- .6 Continuity of the existing cathodic protection system shall be maintained when any additions or replacements are undertaken.

- .7 Hot tapping may be done only with written permission from the Mechanical Utilities Engineer, UBC Energy & Water Services. Phone: 604-822-3274.
- .8 Purge pipe with nitrogen after new service pipe is installed.
- .9 For pipe bedding use clean granular pipe bedding, graded gravel, 10 mm (minus), MMCD type:
 - .1 Bottom bedding shall be a quarter of pipe diameter or 100 mm thick, whichever is larger. Top bedding shall be minimum 300 mm thick. Side bedding shall be a minimum 225 mm to maximum 300 mm thick
 - .2 Trench backfill is to be as per MMCD specifications or as approved by UBC EWS.
- .10 No trees shall be planted within 1,200 mm of underground gas piping.
- .11 Shutdowns must be requested in writing adhering to UBC's campus- wide standard procedures. Refer to <http://www.buildingoperations.ubc.ca/resources/policies-procedures-forms/>.
- .12 Connections to existing gas distribution system may be made by a qualified and EWS approved Contractor with a UBC EWS approved design.
- .13 See also Energy & Water Services' Natural Gas Service Installation work procedure, at <https://energy.ubc.ca/community-services/contractors-developers/>.
- .14 Gas distribution valves and meter stations on the UBC Energy & Water Services system may only be operated by UBC Energy & Water Services.
- .15 Records of pipe sizes and inverts shall be provided to Infrastructure Development, Records; and to UBC Energy & Water Services; in accordance with Sections 01 78 39 Project Record Documents and 33 00 10 Underground Utilities Services of these guidelines.

*****END OF SECTION*****

1.0 **GENERAL**

1.1 **Introduction**

- .1 The University of British Columbia has collated two reports that FVB (FVB Energy Inc.) prepared: Technical Design Basis Document – for Hot Water Energy Transfer Stations and for Hot Water Distribution Piping System. FVB prepared these documents to outline the design basis for the building connections of Energy Transfer Stations (ETS) and required building secondary side modifications for the conversion to a medium temperature hot water district energy system; as well as to outline the technical guidelines or design basis of the new hot water District Energy System (DES). This section will serve as the general technical reference guide on which all design would be based. No significant changes to this concept shall be made without the approval of UBC Energy and Water Services (EWS). DES pipe installation work is restricted to Logstor - trained and certified contractors only.

A copy of such certification must be attached to the bid.

1.2 **System Description**

- .1 The University of British Columbia (UBC) has a medium temperature hot water district heating system at the Vancouver (Point Grey) UBC North Campus.
- .2 The hot water is being distributed to each customer/building on the campus through a two-pipe (one supply and one return) buried distribution piping network. The hot water is used for building heating and domestic hot water heating. The purpose of the energy transfer station is to transfer the energy transported from any Heating Plant through the distribution network to the customer via heat exchangers to satisfy the buildings' heating needs. The energy transfer stations therefore replace the steam converters in existing buildings or the traditional boiler or furnace system and hot water heaters in new buildings. The building heating system design for new buildings is open to the designer as long as the system meets the basic requirements of the District Heating system.
- .3 The medium temperature hot water system operates at a maximum supply temperature of 120°C on peak design days and a maximum return temperature of 75°C. The design pressure for this system is 1,600 kPa.
- .4 The DH system employs a variable flow and supply water temperature strategy that will vary both parameters based on outside air temperature and load demand. Each building will be connected to the distribution system indirectly through an energy transfer station. The actual load delivered to each customer is controlled by modulating motorized control valve(s) located on the distribution system side (or primary DH side) of the energy transfer station. This variable flow and temperature reset strategy is to aid in maximizing the efficiency of the entire system.

1.3 **Energy Transfer Station (ETS) Basic Equipment**

- .1 An energy transfer station is made up of heat exchanger(s), isolation valves, strainers, control package – including controller, control valve(s), temperature sensors, and energy metering package – including flow meter, temperature transmitters, and energy calculator.

1.4 **Definition**

- .1 **Building Energy Transfer Station (ETS)** – The building ETS is an interconnection between the DH system and the consumer's hot water heating and domestic hot water systems. The ETS is an indirect connection to the customers' systems via heat exchangers. The ETS consists of isolation and control valves, controllers, measurement instruments, an energy meter, heat exchanger(s), pipe, pipe fittings, and strainers.

- .2 **Campus Energy Center (CEC)** – Main District Heating Plant located in its own building at the corner of Health Sciences Mall and Agronomy Road.
- .3 **DH** – The District Heating system
- .4 **DES- The District Energy System (same as above)**
- .5 **Design Engineer** – The entity that is responsible for the design of the energy transfer stations or distribution piping system.
- .6 **Design Pressure** – The design pressure shall be the maximum allowable working pressure as defined in ASME B31.1 Power Piping Code.
- .7 **Development/Owner’s Engineer** – The entity hired by the owner to oversee and review the work by the contractor and Design Engineer.
- .8 **Distribution Piping System (DPS)** – The network of main piping lines connecting the DH Energy Centre to the service line piping. The direct buried supply and return distribution lines for the hot water system will be Logstor prefabricated, pre-insulated steel pipes.
- .9 **DHW** – Domestic Hot water
- .10 **DPS Leak Detection System (LDS)** – Logstor designed System that consists of measuring sections and measuring instruments for surveillance of the integrity of the pipe system. The LDS is designed to detect moisture within pipe insulation, system deviations and disorders and the location of moisture and/or disorders.
- .11 **Energy Meter** – The energy meter is made up of a flow meter, two matched pair of temperature sensors, and an energy calculator/integrator. The meter will continuously display operating parameters (i.e. flow, demand, temperatures, etc.) on the LCD screen. This information is used for metering and billing purposes. The meters are to be integrated with Owner’s ION metering system.
- .12 **Heat Exchanger (HX)** – The heat transfer equipment is used in extracting heat from one system and passing it to another system. Heat exchangers are used between the DH system and the customer heating systems.
- .13 **Heating Plant** – The District Heating source, to which the distribution network connects.
- .14 **Interconnecting Pipe** – The interconnecting pipes run from the main isolation valves inside the building wall to the ETS heat exchangers located in the customer’s mechanical room.
- .15 **Medium Temperature Hot Water (MTHW)** – Treated water used in the heating distribution and service line network. MTHW systems are designed for maximum design supply temperatures of 120°C.
- .16 **Operating Pressure** – The operating pressure is the pressure at which the system normally operates.
- .17 **Owner** – The entity, University of British Columbia (UBC), with whom the contractor has entered into the agreement and for whom the work is to be provided.
- .18 **Service Line (pipe)** – The service lines run from the branch fittings on the main distribution pipes to a maximum of 3 meters inside the building wall. A set of isolation valves are normally installed at the point where the service line penetrates the building wall.
- .19 **Strainer** – Strainers are required at both the hot and cold side inlets of all heat exchangers to protect the heat exchangers from any suspended particles and debris. The primary side strainers will also protect the control valves and flow meters.

1.5 Building Connections

- .1 The heating ETS for the customers will be designed so that each building can be “indirectly” connected to the main distribution system. This means that each building’s internal heating and domestic hot water systems (secondary side) are isolated from the DH distribution system (primary side) by means of a brazed plate (or double wall plate & frame for DHW) heat exchanger(s).
- .2 The basic ETS will consist of the isolating valves, heat exchangers, actuated control valves, a digital controller, and an energy meter. The controller is used to sense the heat load demanded by the building and satisfies the heating demand by modulating the two- way control valves located on the primary side return of the ETS. This modulating action allows either more or less heat to be made available for transfer to the building’s internal heating system.
- .3 New buildings must utilize a cascading of the space heating heat exchangers and domestic hot water (DHW) heat exchangers as this is beneficial to improve the return water temperatures.
- .4 General arrangement is found in Standard Documents (see 2.1.1). Also see Division 23, Section 23 21 00 Hydronic Systems – Piping & Equipment.

2.0 **GENERAL REQUIREMENTS**

2.1 **Responsibilities**

- .1 UBC Energy & Water Services (EWS) is primarily responsible for operation, maintenance, and overall stewardship of the district energy hot water distribution system. The demarcation of UBC Energy & Water Services point of service is normally up to and including the first isolation valve inside the building. Energy & Water Services also owns and maintains any energy meters.
- .2 New building design and construction, in regards to the District Heating System tie-in and the ETS configuration, must be coordinated with UBC EWS. UBC EWS must give approval of the consultants and contractors for the design, installation and commissioning of these systems.
- .3 Key positions in UBC Energy & Water Services are described in Division 33, Section 3300 10 Underground Utilities Services of UBC Technical Guidelines.
- .4 Unless otherwise agreed in writing, the project Designer is responsible for all design, permit, and inspection requirements of Technical Safety BC (TSBC) and all other regulatory bodies involved.
- .5 The project Designer must incorporate all specific requirements for metering, design and materials and execution of this section into the contract drawings in the form of job-specific notes. Only making reference to UBC Technical Guidelines in the drawings is not sufficient.
- .6 Shutdowns must be requested in writing adhering to UBC's campus-wide shutdowns procedures. Refer to Service Shutdown Request at <https://buildingoperations.ubc.ca/resources/policies-procedures-forms/>
- .7 Operating valves on the district hot water energy distribution system shall only be performed by UBC Energy & Water Services.

2.2 **District Hot Water Energy Distribution Standards and Policies**

- .1 DES Codes and Standards
 - .1 The design, fabrication and installation of the distribution system shall be in accordance with the laws and regulations of the Province of British Columbia, CSA B51 and ASME B31.1. All primary side ETSs must be designed and registered with Technical Safety BC. Stress analysis should be performed at 120°C for both supply and return piping.
 - .2 In addition, the distribution system shall be designed and installed in accordance with the latest editions of the applicable Codes and Standards from the following authorities:
 - British Columbia Building Codes, Technical Safety BC
 - American Society of Heating, Refrigeration and Air Conditioning Engineers (ASHRAE)
 - Air Conditioning and Refrigeration Institute (ARI)
 - American Society of Mechanical Engineers (ASME)
 - American Society of Testing and Materials (ASTM)
 - American National Standards Institute (ANSI)
 - American Water Works Association (AWWA)
 - American Petroleum Institute (API)
 - Instrument Society of America (ISA)
 - Underwriter's Laboratories (UL)

- National Electrical Manufacturer's Association (NEMA)
- National Fire Protection Association (NFPA)
- American Standards Association (ASA)
- American Welding Society (AWS)
- Canadian General Standards Board (CGSB)
- Canadian Standards Association (CSA)
- Manufacturers Standardization Society (MSS)
- European Standards EN253, 1434, 448, 488, & 489.

As well as UBC Sustainability Development Policy # 5:

[\(https://universitycounsel.ubc.ca/board-of-governors-policies-procedures-rules-and-guidelines/policies/\)](https://universitycounsel.ubc.ca/board-of-governors-policies-procedures-rules-and-guidelines/policies/).

.2 ETS Codes and Standards

.1 The design, fabrication and installation of the energy transfer stations shall be in accordance with the laws and regulations of the Province of British Columbia. All primary side ETSs must be designed and registered with Technical Safety BC. Stress analysis should be performed at 120°C for both supply and return piping.

.2 In addition, the energy transfer stations shall be designed and installed in accordance with the latest editions of the applicable Codes and Standards from the following authorities:

- ASHRAE Standard 90.1 - Energy Standards for Buildings
- British Columbia Building Code
- CSA B51 –Boiler, Pressure Vessel, and Pressure Piping Code.
- CSA C22.1-2002 – Canadian Electrical Code, British Columbia Electrical Safety Code and Bulletins, and regulations of the local inspection authority.
- Safety Standards for Electrical Equipment, Canadian Electrical Code, Part II.
- The Environmental Protection and Enhancement Act enforced by British Columbia Environment.
- ANSI/ASME B31.1 Power Piping Code and piping system to be registered with Provincial Boiler Safety Authority.
- ANSI/ASME Boiler and Pressure Vessel Code, Section VIII.
- American Society of Testing and Materials (ASTM)
- Underwriter's Laboratories (UL)
- Canadian General Standards Board (CGSB)
- Canadian Standards Association (CSA)
- Manufacturers Standardization Society (MSS)
- Technical Safety BC

As well as UBC Sustainability Development Policy # 5:

[\(https://universitycounsel.ubc.ca/board-of-governors-policies-procedures-rules-and-guidelines/policies/\)](https://universitycounsel.ubc.ca/board-of-governors-policies-procedures-rules-and-guidelines/policies/)

2.3 District hot water energy Distribution Service Connections

.1 The first step to install any new or substantially modified connections to the district hot water energy distribution system at UBC is complete a Utility Service Connection Application. This and other forms can be found at <https://energy.ubc.ca/community-services/contractors-developers/>.

.2 Any new connections to the district hot water energy distribution system will be reviewed for consistency with UBC Energy & Water Services standards as defined in the UBC Technical Guidelines.

.3 The Designer shall obtain the District hot water energy service records by contacting the Records Clerk at Infrastructure Development, Records Section (Telephone: 604-822-9570) and develop proposed service connection location(s).

3.0 **DISTRICT HOT WATER ENERGY DISTRIBUTION DESIGN OVERVIEW AND CONCEPTS**

3.1 Design Requirements for DPS

.1 **Pipe Velocities**

Buried Mains & Mains in Tunnels	2 – 3.5 m/sec
Max. Water Velocity in Service Lines	2 m/sec

.2 **Temperatures**

System Rated Supply Temp.	120°C
System Operating Supply Temp.	70°C
Max. Return Temp.	75°C
Min. Return Temp.	35°C
System Operating delta-T	30°C

.3 **Pressures**

System Design Pressure	1,600 kPa
System Operating Pressure	1,450 kPa
System Test Pressure	1.5 x Design Pressure

.4 **Buried Piping**

Normal Depth of Bury	900-1200 mm
Minimum Depth of Bury	600 mm
Minimum Trench Slope for Drainage	0.50%

.5 The design conditions listed below are general in nature and are to be used for preliminary line sizing. Major extensions or additions to the system should be sized based on a detailed system hydraulic model.

.6 **TSBC Registration**

.1 All aspects of the DPS shall be designed and registered with TSBC.

.7 **Thermal Expansion & Pipe Stress**

.1 The recommended method to design for pipe stress resulting from thermal expansion is through the use of compensators, expansion pipe sold by Logstor ,expansion bends and U- loops.

.8 **Seismic Considerations**

.1 The piping design will incorporate the requirements of TSBC to meet the seismic loading outlined in the latest version of the BC Building Code.

.9 **Water Hammer**

.1 For larger systems or systems with pipe velocities exceeding 3.5 m/s, design consideration should be given for water hammer. The piping design will consider the necessity of water hammer control.

.10 **Hydro Test and Flushing**

.1 Design consideration should be given for every DPS section Flushing and Hydro Testing before it is connected to existing Close Loop. It should be either reflected in DPS drawings or written instructions to the Contractor.

.11 **DPS Zoning**

.1 DPS shall be designed and constructed with adequate amount of Zone Isolation Valves. This is to minimize the negative impact of heat loss in case of necessity to isolate DPS section for upgrade or repair.

.12 **DPS Vents and Drains**

.1 The piping design should incorporate air vent valves at every highest point of DPS to avoid air pockets. All buried high point vents and drains to be a pre-insulated branch tee with service valve and valve to be a forged valve. Boehmer or equivalent. The vent to be a min size of 38mm. Consideration should be given to provide means of draining for every DPS Zone. Drain valves at the end of Service Lines may serve the purpose and should not be missed.

.13 **DPS Leak Detection System (LDS)**

.1 DPS LDS should comply with **EN 14419** of latest edition:
 .1 Design Engineer (DE) should provide a detailed wiring diagram of LDS to contractor and EWS before DPS assembly takes place. Specification of measuring wires assembly instructions, should accompany the wiring diagram.
 .2 Specification of LDS assembly check with description of equipment required to be provided by DE. DE also to provide guidelines for LDS functional test procedure, description of equipment required for above test, specification of a fault simulation test and data for acceptable test values.

3.2 Design Parameters for ETS

.1 **Piping Sizing Criteria¹**

.1 Pressure Gradient Used to Determine Max. Water Velocity in Service Lines: Based on 250 Pa/m Pressure Gradient.

.2 **Pressures**

ETS Primary Side Operating ΔP	150 – 550 kPa
Customer Side Design Pressure	≤1,600 kPa
Customer Side Operating Delta P	As required
System Test Pressures	1.5 x Design Pressure

.3 **Temperatures**

		DES Rated Conditions	ETS Selection Criteria
District Heating Side	Supply Temp ² .	120°C	70°C
	Return Temp.	<55°C	<40°C

.1 ETS HX's shall be selected at 70°C EWT from the DES, but be rated to 120°C. See section 4.1.4 for more details.

.4 Low Temperature buildings are preferred to maximize the ΔT and improve system performance (see UBC Technical Guidelines Section 23 05 00 2.1.1).

.5 The design conditions listed above are general but conform to industry standard and will be used for preliminary line and equipment sizing.

¹ Indicated criteria are recommended in accordance with ASHRAE pipe design flow ranges.

² Temperatures will be reset based on outside air temperature for energy conservation purposes. The coolest water possible will be delivered to the customer that will still meet the customer's heating criteria and needs.

3.3 Hot Water General

- .1 Optimization of the hot water distribution system delta T (ΔT) is critical to the successful operation of the DH system. Therefore, the customer's ΔT must be monitored and controlled. In order to optimize the DH system ΔT and to meet the customer's hot water demand, the hot water flow rate from the DH plant will vary. Varying the flow rate to satisfy demands saves pump energy for the DH system.
- .2 New buildings' HVAC systems shall employ variable flow hot water heating systems to heating coils which forms an integral part of the HVAC systems by means of two-way modulating valves or three-way mixing valves only (diverting three-way valves lower the delta T and therefore are not recommended). The aforementioned design strategy is strongly recommended as it will save energy costs for UBC.
- .3 The energy calculations shall be performed via the energy meter based on input from the flow meter and two temperature sensors.

3.4 Pressures

- .1 The DH primary system is designed for a maximum allowable working pressure of 1,600 kPa. Equipment (valves, fittings, etc.) installed for the ETS locations will, where applicable, be selected to minimum ANSI Class 150. The ΔP at each service connection will vary depending on its location in the distribution system.
- .2 The Design Engineer shall request the estimated available distribution pressures for each ETS connection from the Owner's Engineer. These pressures typically include an estimate for 10 metres of interconnecting piping downstream of the main isolation valves at the building penetration. A minimum of 150 kPa will be allocated for the critical customer, which includes the ETS equipment and interconnecting piping. Customers closer to the heating plant may be able to support a higher allowable pressure drop. Final calculation of all internal pressure drops are the responsibility of the Design Engineer.

.1 Static Pressure

- .1 The DES system has to be sufficiently pressurized at the plant to overcome the elevation difference in the system and to avoid boiling (or flashing) from occurring at the high points. In addition, some further margin is required to minimize the effect of operating disturbances, such as cavitation and pressure surges (i.e. transient pressures). Higher static pressure requirements will limit the maximum allowable dynamic pressure in the system set by the design pressure of 1,600 kPa. This again could put unnecessary limitations on the system capacity.
- .2 Thus, it is generally recommended to install ETSs at the basement or ground floor level to ensure that the building elevations do not put unwanted static pressure limitations on the system.

4.0 MAJOR EQUIPMENT DESCRIPTION

The ETS includes equipment the necessary pipes, heat exchangers and associated controls and energy meters. This equipment should be located inside the customer building mechanical room **in the basement**. See Figure 1 and Figure 2 below as an example of a typical ETS located at an exterior wall near the DPS mains in the street.

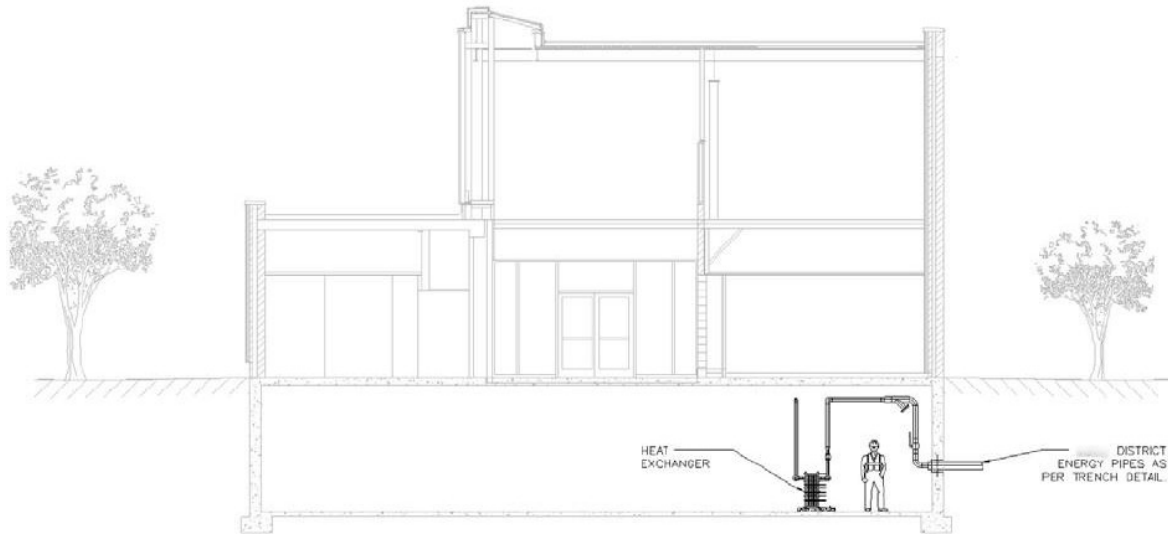

FIGURE 1 TYPICAL ETS INSTALLATION IN BUILDING BASEMENT

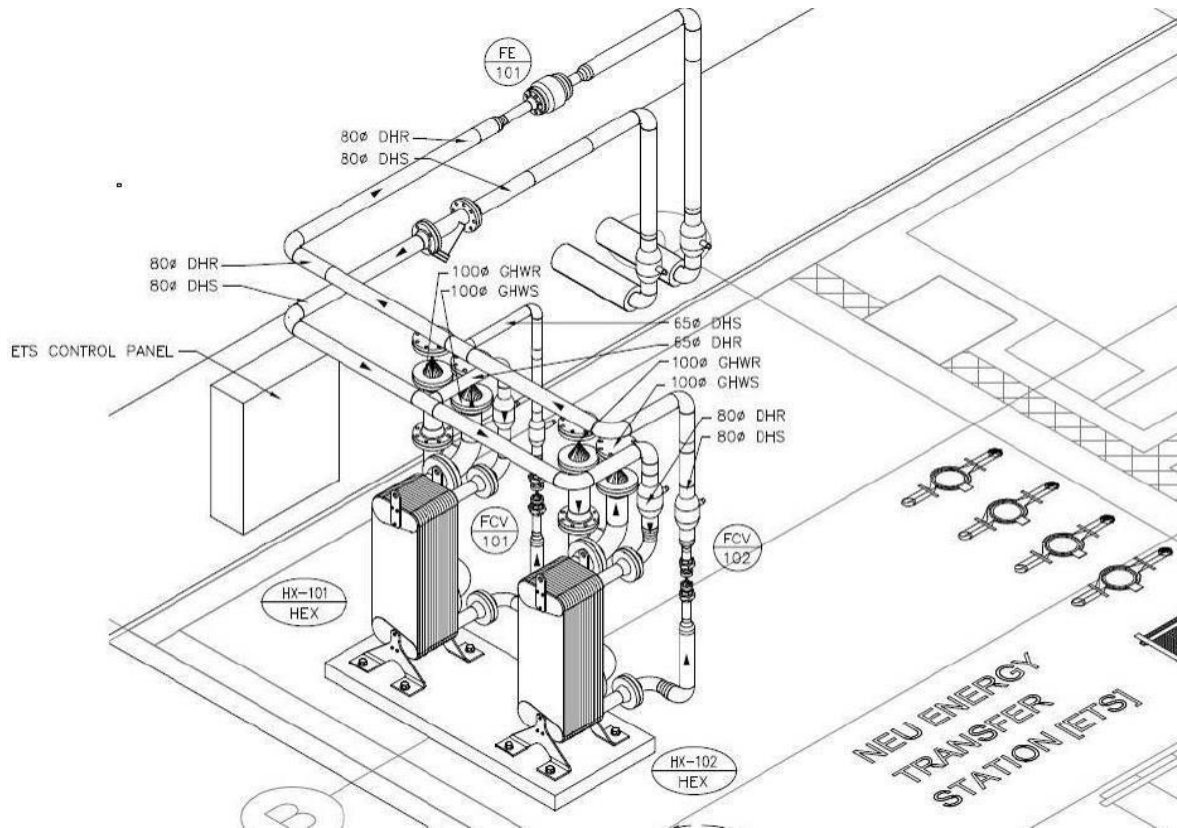

FIGURE 2 TYPICAL ETS (DETAIL)

4.1 Heat Exchangers

- .1 Heat exchangers will be used on connections to all buildings to separate the existing building heating system from the DES (i.e. indirect connection). The optimum selection of each HX will be analyzed on the basis of:
 - .1 Sizing each unit's capacity to match the load and load turn-down as close as possible.
 - .2 Critical nature of the load/operation.
 - .3 Temperature and pressure conditions.
 - .4 Available space in mechanical room.
 - .5 Allowable ΔP on both sides of HX.
- .2 Brazed Plate heat exchangers for space heating, and double-wall brazed plate or double walled plate and frame with end plate leak detection for domestic hot water are required for this application. Shell & tube heat exchangers should not be used. Also see Division 20, Section 20 00 05 Mechanical General Requirements, 2.3.3.
- .3 **New buildings with coincidental heating and domestic hot water requirements (i.e. Student residences) shall utilize a cascaded design.**
- .4 The following table summarizes the selection criteria:

.1 **Space Heating Heat Exchanger Selection Criteria New Buildings⁴**

Hot Side Conditions			Cold Side Conditions		
Inlet Temp	Outlet Temp	Max. ΔP	Inlet Temp	Outlet Temp	Max. ΔP
70°C	40°C	50 kPa	35°C	46°C	35 kPa ⁴

- .2 Each HX will be sized for a maximum 5°C approach on the hot side (DH side) outlet to cold side inlet. Higher customer return temperatures and ΔT s will have an adverse impact to the overall system operation and performance.

.3 **Domestic Hot Water Heat Exchanger Selection Criteria**

Hot Side Conditions			Cold Side Conditions		
Inlet Temp	Outlet Temp	Max. ΔP	Inlet Temp	Outlet Temp	Max. ΔP
70°C	35°C	50 kPa	5°C	60°C	50 kPa

.4 **Cascaded Domestic Hot Water Pre-Heat Exchanger Selection Criteria**

Hot Side Conditions			Cold Side Conditions		
Inlet Temp	Outlet Temp	Max. ΔP	Inlet Temp	Outlet Temp	Max. ΔP
70°C	35°C	50 kPa	5°C	55°C	50 kPa

- .5 Note: The Cascaded DHW Pre-heat exchanger is to be sized for the full flow from both Hot water and DHW heat exchangers with a maximum ΔP of 50 kPa on the DH side. See standard drawings for further details.

⁴ May vary at each building location. Existing building allowable pressure drop to be reviewed on a case- by-case basis. Generally, since existing pumps are expected to be reused, the pressure drop should be selected to match the pressure drop of existing equipment.

- .6 The design pressure on the hot side (DH) of the HX will be 1,600 kPa. On the cold side, the design pressure will be determined by the building hot water system pressure. The maximum cold side pressure will be 1,600 kPa.
- .7 All heat exchangers shall have a Valid CRN for British Columbia with a supplied Manufacturers Data report (MDR).

4.2 Hot Water Control Parameters

- .1 As stated previously, the DH supply temperature may vary between 70°C and 120°C. The supply water temperature is lowered outside the peak conditions for the purpose of conserving energy. The secondary return temperature must be no higher than 50°C for new buildings. The objective of the control system is to provide as cool a supply temperature as possible that will still meet the customer's capacity requirements while maximizing the ΔT between the District Heating Supply and Return (DHS&R) distribution piping. The minimum DH supply temperature is limited to 70°C in summer in order to meet the requirements of the domestic hot water systems whose storage tanks must be maintained at minimum 60°C to prevent bacteria growth (i.e. Legionella) in the system.

4.3 Control & Measuring Equipment Performance

- .1 Each ETS will have a control & metering panel responsible for calculating energy consumed at each ETS and maintaining proper temperature relationships between the DH system supply and each building. It is recommended to use two control valves i.e. 1/3 & 2/3 split range for flow rates larger than 5 L/s for larger turn down. Alternatively, a 50/50% split can be used if higher redundancy is desired.

4.4 Energy Meters

- .1 It is critical that high-quality integrated energy meters are used to achieve optimum metering accuracy and performance. Magnetic (preferred) or ultrasonic flow meters are recommended to be used at each building ETS. In addition, the integrated meters comprise of matched pair platinum temperature sensors and a sealed factory programmed integrator (i.e. calculator). These meters meet existing international standards (OIML R75 and EN1434) for thermal energy metering, as well as the Canadian standard (CSA C900). Magnetic (preferred) and ultrasonic flow meters have relatively low pressure drops, good range ability and accuracy while requiring very little maintenance. Also, the minimum straight run requirements are greatly reduced (5 diameters upstream and 3 diameters downstream) as compared to some other types of meters.

4.5 Networking Communications

- .1 The Communication network will provide the communication link between each customer ETS and the plant. This will allow remote monitoring, control of each ETS. Metering will be connected to the Campus wide ION network.
- .2 The Communication network will be routed through UBC's IT network and connected into the campus wide BMS system. Siemens and ESC are preferred vendors.

4.6 DPS Leak Detection System (LDS) EN 14419

- .1 LDS should be assembled as per DE instructions with Logstor components. After finishing of each measuring section, it should be tested for:
 - .1 Continuity of measuring wires
 - .2 No electrical contact or moisture between the wires and pipes

- .2 Upon assembly of LDS zone, the System functional test is to be conducted with fault simulation.
- .3 All data is to be recorded and presented to DE and EWS complete with as-built drawings with leak detection resistance listed for each joint.
- .4 After 4 weeks of operation LDS functional test should be repeated by contractor and result to be recorded. Test is to be witnessed by EWS representative.
- .5 Before extending or renovating of existing LDS the actual state of System should be measured and documented:
 - .1 Wiring ohmic resistance from conductor to conductor
 - .2 Isolation resistance from conductor to pipe.

4.7 Differential Pressure sensor

- .1 An electronic differential pressure sensor will be fitted between the inlet and return on the primary side. It must be capable of being read locally as well as have an output to allow it to be read remotely (network connection). (Endress and Hauser or Rosemount are preferred.)

5.0 **MAJOR EQUIPMENT SPECIFICATIONS**

5.1 **Piping Material**

.1 **Buried District Energy Distribution Piping EN253**

SCOPE: This section specifies prefabricated and pre-insulated piping for direct burial installation as a hot water DES. Fluid temperatures are limited to the range 4°C to 120°C.

.1 **System Function**

- .1 The DES shall be installed as a fully welded and bonded system in which the steel carrier pipe, insulation and outer casing are bonded together to form a solid unit. This solid unit when buried is completely sealed from soil and water ingress and hence provides superior longevity and performance. It is critical for owners to find suppliers of complete buried systems rather than applying a significant effort in assembling components from multiple suppliers to provide a completely sealed system. Piping System shall conform to EN253 standards (Logstor or approved equal).
- .2 The system comprises a steel carrier pipe, polyurethane foam insulation with integral copper alarm wires, and an outer casing of high density polyethylene. The system shall be designed such that the expansion movements of the steel carrier pipe are transferred to the outer casing via the foam insulation. The elements of the bonded pipes shall be manufactured to expand and move together. The movements are restricted by the friction between soil and jacket pipe, which acts as the anchorage for the pipe system. Generally external anchors are not required.
- .3 Expansion is allowed for as determined by the stress analysis (see Section 3.9 for methods used to reduce pipe stress due to thermal expansion).

.2 **District Energy Distribution Piping in Tunnels and in Buildings**

SCOPE: This section specifies welded piping that is insulated on site for installation in the existing tunnel system and in buildings. Fluid temperatures are limited to the range of 4°C to 120°C.

.1 **System Function**

- .1 The distribution piping system shall be installed as a fully welded system.

.2 **Tunnel & Building Pipe Material**

- .1 All tunnel and building distribution piping will be designed, constructed, and tested in accordance with ASME B31.1 Power Piping Code. In general, all tunnel and building distribution piping is of welded carbon steel construction (A53 schedule 40 typical and standard weight in the larger pipe dimensions).
- .2 Mechanical groove joint piping systems will not be accepted in this service.
- .3 Piping will be designed, specified, constructed, installed and registered with TSBC.
- .4 The transition from the buried EN253 pipe to standard weight tunnel or building piping will occur after the wall penetration.

.3 **Tunnel and Building Pipe Leak Detection**

- .1 There will be no leak detection system in the tunnel piping portion. Termination of the leak detection system in the buried piping will be determined at the design phase in consultation with EWS as well as the best method of communication to the monitoring center.
- .2 The leak detection system terminates upon entry into each building.

5.2 Heat Exchangers

.1 Brazed Plate Heat Exchanger – Space Heating

- .1 Heat exchangers shall consist of thin corrugated Type 316 stainless steel plates stacked on top of each other and brazed together. Brazing material shall be copper. Every second plate shall be inverted so that a number of contact points are created between the plates. The plate patterns are to create two separate channels designed for counter flow.
- .2 Plate thickness shall be of a minimum of 0.4mm. The plate pack shall be covered by Type 316 stainless steel cover plates.
- .3 The flanged connections shall be located in the front or rear cover plate. Flanged nozzle connections shall conform to ASA standards, and shall be of the pressure rating design indicated below.
- .4 Heat exchangers shall be supplied with removable insulation jackets, support stands and brackets. Stainless steel or OEM.
- .5 The heat exchangers shall be designed for the following continuous operating pressures and temperatures: 1,600 kPa and 120°C, hot water
- .6 Heat exchangers must be mounted according to manufacturer's requirements.
- .7 The heat exchanger characteristics shall be as per the attached schedule.
Standard of Acceptance: Xylem, Alfa Laval or equivalent

.2 Double Wall Plate & Frame Heat Exchangers – Domestic Hot Water

- .1 Frame shall be carbon steel with baked epoxy enamel paint. The frame shall be designed without additional welds and reinforcements. The carrying and guide bars shall be bolted to the frame, not welded. The carrying and guide bar surface in contact with the plates and roller shall be made of, or clad with a corrosion resistant material such as stainless steel. The bolts shall be greased with molybdenum grease and protected with plastic sleeves.
- .2 Connections shall be a flanged connection. Flanged connections shall conform to ASA standards.
- .3 The double wall plates shall be composed of two plates pressed together simultaneously and laser welded at the port. Failure of one plate or weld shall result in an external detection without inter-leakage. The plates shall be corrugated Type 316 stainless steel. Metal to metal contact shall exist between adjacent plates. The plates should have no supporting strips and should be pressed in one step. The part of the plate in contact with the carrying and guiding bars shall be reinforced to prevent bending and twisting during the handling of the plates. The plates shall be fully supported and fully steered by the carrying bar and guided by the guide bar to prevent misalignment in both vertical and horizontal directions. Plate design shall permit the removal of any plate in the pack without the need to remove all of the other plates ahead of it.
- .4 Plate thickness shall be of a minimum of 0.4mm.
- .5 The use of spiral wound gaskets on all primary flanged faces is required.
- .6 The heat exchangers shall be designed for the following continuous operating pressures and temperatures: 1,600 kPa and 120°C, hot water.
- .7 The heat exchanger capacities shall be as per design specifications. Standard of Acceptance: Xylem or equivalent.

.3 Double walled Brazed Plate Heat Exchangers - Domestic Hot Water

1. Heat exchangers shall consist of thin corrugated Type 316 stainless steel plates stacked on top of each other and brazed together. Brazing material shall be copper. Every second plate shall be inverted so that a number of contact points are created between the plates. The plate patterns are to create two separate channels designed for counter flow.
- .2 Plate thickness shall be of a minimum of 0.4mm. The plate pack shall be covered by Type 316 stainless steel cover plates.

-
- .3 The flanged connections shall be located in the front or rear cover plate. Flanged nozzle connections shall conform to ASA standards, and shall be of the pressure rating design indicated below.
 - .4 Heat exchangers shall be supplied with removable insulation kits and supports (stands and, brackets if required etc.). The insulation shall consist of Freon free insulation (polyurethane foam) and ABS plastic cover at a minimum.
 - .5 The heat exchangers shall be designed for the following continuous operating pressures and temperatures: 1,600 kPa and 120°C, hot water
 - .6 Leak detection holes must be visible on the front cover plate of the heat exchanger and must not be covered.
 - .7 Heat exchangers must be mounted according to manufacturer's requirements.
 - .8 The heat exchanger characteristics shall be as per the attached schedule. Standard of Acceptance: Xylem, or equivalent.

5.3 Controls & Measuring Equipment

.1 Description

- .1 The controls are made up of programmable controllers, temperature sensors, outdoor sensors, control valve stations and other miscellaneous instrumentation. The controls and energy metering systems shall be integrated and compatible with the existing building automation system (BAS) and with a compatible communication protocol to perform the functions described in this section. All devices and equipment shall be approved for installation by the Owner and/or Owner's Engineer.
- .2 All controls shall be BACnet compatible.

.2 Products

- .1 The controls supplier shall select the appropriate control component to match the required service conditions. The control valves type selected shall meet the minimum design requirements described in the following sections.
- .2 The minimum test for control valves and flow meters shall be hydrostatic test in strict accordance with the requirements of ASME Section VIII, Division 1, or Section III, Class 3.
- .3 Hydrostatic test pressure shall be 1.5 times the design pressure using calibrated pressure gauges.

.3 Control Valves

- .1 Control valves are to be sized by control supplier according to design specification herein. Water valves shall be sized on the basis of minimum 50% of available differential pressure or minimum 75 kPa (11 psi) pressure drop. Pressure drop for valves shall be submitted for review, including all CV values.
- .2 Valves shall be equal percentage type, two-way, single-seated, and equipped with characteristic type throttling plug, #316, stainless steel stem and seat. Provide with necessary features to operate in sequence with other valves and adjustable throttling range as required by the sequence of operations.
- .3 Valves shall be able to handle a minimum of 345 kPa (50 psi) differential pressures for modulating service with range ability greater than 100:1. Actuator selection shall be for close-off pressures greater than 690 kPa (100 psi). Arranged to fail-safe as called for tight closing and quiet operating. Leakage shall be less than 0.1% of Cv. **Standard of Acceptance: Siemens or equivalent.**
- .4 All two way controls valves shall be slow closing to prevent water hammer.

.4 Electric Actuators

- .1 Provide 24 VAC control valve actuators which are 0-10 VDC or 4-20 mA input proportional with spring return as needed by control sequence and designed for water service valve bodies.
- .2 Operator shall be synchronous motor driven with minimum 750 Newtons of thrust and force sensor safe.
- .3 Control stroke time shall be less than 30 seconds. Actuator shall include a manual clutch that enables manual positioning of valves during power failures and servicing. Upon restoration of power, actuator will automatically reposition itself without intervention. Actuator shall have self-lubricating bearings to minimize maintenance requirements. Indication of position shall be visible at all times. **Standard of Acceptance: Siemens SKB/SKC/SKD or equivalent.**

.5 Energy Metering Components

- .1 The energy meter is made up of a flow meter, two temperature sensors, energy calculator, and plug-in modules. A read-out unit makes it possible for the operator to observe the operating parameters. The energy meter shall be furnished with an output (e.g. Lonworks) for integration with control panel with remote communication capability.
- .2 DES meters shall be network connected for remote monitoring only. The Division 20 contractor shall provide all necessary communication equipment to ensure effective remote monitoring is achieved. Refer to standard drawing E4-6c.
- .3 Energy Calculator shall comply with OIML R75 and EN1434, with accuracy: +/- (0.15+2/ Δt) % and water temperature range 1°C – 160°C and 30 seconds flow calculation intervals. The meter shall have a permanent memory (EEPROM). The meter display shall show the following items:
 - Accumulated thermal energy: MWh
 - Accumulated water flow: m³
 - Actual thermal power: kW
 - Actual water flow: l/h or m³/hr
 - Supply temperature: °C
 - Return temperature: °C
 - Temperature differential: °C
 - Peak thermal power: kW P
 - Peak water flow: l/h or m³/hr P
 - Hour Counter: HRS
- .4 The meter shall be factory calibrated and supplied with verification certificate. **Standard of Acceptance: Endress & Hauser (magnetic) and Kamstrup Ultrasonic or equivalent.**
- .5 The flow meter shall be magnetic or ultrasonic in compliance with OIML R75 and **EN1434**, with accuracy +/- 1.0% of rate within flow range of 0.3 to 9 m/s and minimum rangeability 1:30. Fluid temperature range shall be 4 to 120°C and fluid pressure range full vacuum to 1,600 kPa. Factory calibrated **Standard of Acceptance: Endress & Hauser (magnetic) and Kamstrup Ultrasonic or equivalent.**
- .6 The meter shall be factory calibrated and supplied with calibration certificate. **Standard of Acceptance: Endress & Hauser (magnetic) and Kamstrup Ultrasonic or equivalent.**
- .7 Resistance Temperature Detectors (RTDs) shall be 4-wire PT500 Pocket Sensor

(Paired) with connecting head performance .04°C Δt deviation (pairing). **Standard of Acceptance: Endress & Hauser (magnetic) and Kamstrup Ultrasonic or equivalent.**

.8 Sequence of Operations

.1 General

.1 The general control strategy to be implemented for the new Energy Transfer Stations shall be the supply temperature reset based on the outside air temperature. In addition, a reset function based on return temperature shall be employed to ensure that the District heating return temperatures are maintained as low as possible.

.2 Standard Heating Supply with Return Limiting

.1 During normal operation, the secondary supply temperature shall be set from a temperature reset schedule based on outside air temperature (OAT). The schedules are to be system specific.

.2 The secondary return temperature shall not exceed the maximum return temperature limit. Should this happen, the supply temperature set point shall be reset down until the secondary return temperature drops below the maximum values. The return water limiting function shall override the minimum supply temperature function. The maximum return limit will be building specific.

.3 Domestic Hot Water (DHW)

.1 The controller shall be programmed to fully close the DHW control valve when the recirculation pumps on the secondary side shut off. When the recirculation pumps are turned back on, the controller will be programmed with a 20 second delay, prior to opening the DHW control valve.

.2 During normal operation, the customer domestic hot water supply temperature shall fix set point, initially at 60°C (adjustable range 40 to 65°C.) The controls shall have a Maximum limit (adjustable, initially set at 65°C) when the control valve will go to closed position.

.4 Alarms

.1 The DDC system shall monitor hot water supply and return temperatures. If temperatures exceed high or low limits, an alarm shall be recorded at the operator's workstation.

.6 Leak Detection System Equipment

.1 LDS equipment should be Logstor approved. Ordinary electrical wire or any other kind of unauthorized wire is not allowed to form any part of the LDS assembly.

5.4 Valves – Primary Side Isolation Valves

.1 Design

.1 Valve construction design and tested to EN488 specification

.2 Valve design to be fully welded

.3 Design to be suitable for above and below ground service

.4 For service in district heating, valve shall be suitable for 120 degrees C and 232 psi pressure

.5 Minimum rating PN25 to allow for testing at 1.5 times for system expansion.

.6 Full or reduced bore

.7 Weld ends to schedule 40 for above ground and EN253 for buried service

.8 If flanged ends are required, flanges to be to ANSI

.9 Above ground valves should have a 60 mm extension to allow for insulation

.10 Provide top of stem position indication with a visible groove

.11 Operator – Lever operated up to 6", gearbox for 8" and up

.2 Materials

- .1 Body, only forged materials are accepted, ASTM A106 or A352LF2
- .2 cold pressed steel is not acceptable
- .3 Ball, stainless steel
- .4 Seat PTFE with minimum 25% glass reinforced
- .5 Seat to be spring supported, individual coil springs are preferred
- .6 Stem, stainless steel
- .7 O-rings, EPDM

.3 Buried service

- .1 Valves for buried service to be pre-insulated with polyurethane foam and PE outer protection as per EN253
- .2 Pre-insulation to have leak detection wiring
- .3 Valve should have an integral welded extension to an agreed height
- .4 A minimum of 2 O-rings at the bottom and 2 O-rings at the top of the stem are required to prevent water ingress into the stem assembly
- .5 The assembly should provide an internal mechanical travel stop in the stem extension
- .6 A parallel square nut is to be provided
- .7 Gear operator required for valves size 8" and up (portable)

.4 Valve testing

- .1 All valves to be Hydro shell tested at 1.5 times the rated pressure
- .2 All valves to be seat tested; both seats to be tested at max. 1.1 times the rated pressure
- .3. Acceptable leakage rates for seat tests are to API 598 or rate A of EN12266

5.5 Gaskets

- .1 The use of flexitalic gaskets on all primary flanged faces is required.

6.0 **DISTRICT HEATING PRIMARY PIPING**

6.1 **References**

- .1 ANSI/ASME B1.20.1-1983 (R2001), Pipe Threads, General Purpose.
- .2 ANSI/ASME B31.1- [2004], Power Piping.
- .3 ANSI/MSS SP-58-[2002], Pipe Hangers and Supports – Materials, Design, and Manufacture.
- .4 ASME B16.34-1996 - Valves - Flanged, Threaded, and Welding End
- .5 ASME B31.5 – 2001, Refrigeration Piping and Heat Transfer Components.
- .6 ASTM A47/A47M-99(2004), Ferritic Malleable Iron Castings.
- .7 ASTM A53/A53M-05, Pipe, Steel, Black and Hot-Dipped, Zinc-Coated Welded and Seamless.
- .8 ASTM A105/A105M-05, Carbon Steel Forgings for Piping Applications.
- .9 ASTM A106/A106M-04b, Seamless Carbon Steel Pipe for High Temperature Service.
- .10 ASTM A108-03, Steel Bar, Carbon & Alloy, Cold-Finished.
- .11 ASTM A126-04, Gray iron Castings for Valves, Flanges, and Pipe Fittings.
- .12 ASTM A181/A181M-01, Carbon Steel Forgings for General-Purpose Piping.
- .13 ASTM A193/A193M-05, Alloy-Steel and Stainless Steel Bolting Materials for High-Temperature Service.
- .14 ASTM A194/A194M-05b, Carbon and Alloy Steel Nuts for Bolts for High-Pressure or High Temperature Service, or both.
- .15 ASTM A216/A216M-04, Steel Castings, Carbon, Suitable for Fusion Welding, for High-Temperature Service.
- .16 ASTM A234/A234M-05a, Piping Fittings of Wrought Carbon Steel and Alloy Steel for Moderate and High Temperature Service.
- .17 ASTM A278/A278M-01, Gray Iron Castings for Pressure-Containing Parts for Temperatures Up To 650°F (350°C).
- .18 ASTM A307-04, Carbon Steel Bolts and Studs, 60,000 psi Tensile Strength.
- .19 CAN/CGSB-14.5-[M88], Thermometers, Bimetallic, Self-Indicating, Commercial/Industrial Type.
- .20 CSA B51 - 03 Boiler, Pressure Vessel, and Pressure Piping Code.
- .21 MSS SP-67-2002a, Butterfly Valves.
- .22 MSS SP-70-1998, Cast Iron Gate Valves, Flanged and Threaded Ends.
- .23 MSS SP-71-1997, Grey Iron Swing Check Valves, Flanged and Threaded ends
- .24 MSS SP-72-1999, Ball Valves with Flanged or Butt-Welding Ends for General Service.
- .25 MSS SP-80-2003, Bronze Gate, Globe, Angle and Check Valves.
- .26 MSS SP-85-2002, Cast-Iron Globe and Angle Valves Flanged and Threaded Ends.
- .27 MSS SP-58-[2002], Pipe Hangers and Supports – Materials, Design, and Manufacture.
- .28 EN253 Pre-insulated Bonded Piping Systems (European Standard)
- .29 EN448 Pre-insulated Fitting Assemblies (European Standard)
- .30 EN488 Pre-insulated Steel Valve Assemblies (European Standard)
- .31 EN489 Joint Assemblies on Pre-insulated Pipes (European Standard)
- .32 DIN 1626, Steel Quality St 37.0 (ASME-A53 Grade B Equal)
- .33 ISO4200/DIN2458 – Plain End Steel Tubes, Welded and Seamless - Measurements and weights
- .34 ANSI/ASME B31.1 – (Latest), Power Piping.
- .35 ANSI/ASME B31.9 – (Latest), Building Services Piping.
- .36 ANSI/ASME Boiler and Pressure Vessel Code-(Latest):
- .37 Section 1: Power Boilers.
- .38 Section V: Nondestructive Examination.
- .39 Section IX: Welding and Brazing Qualifications.
- .40 CSA W48-01, Filler Metals and Allied Materials for Metal Arc Welding.
- .41 CSA B51-03, Boiler, Pressure Vessel and Pressure Piping Code.
- .42 CAN/CSA-W117.2-01, Safety in Welding, Cutting and Allied Processes.

- .43 CSA W178.1-02, Certification of Welding Inspection Organizations.
- .44 CSA W178.2-01, Certification of Welding Inspectors.
- .45 CGSB 48.2-92, Spot Radiography of Welded Butt Joints in Ferrous Materials.
- .46 AWS B2.1:2005, Welding Procedure and Performance Qualification.
- .47 AWS C1.1M/C1.1-2000, Recommended Practices for Resistance Welding.
- .48 AWS W1:2000, Welding Inspection.
- .49 ANSI/AWWA C206-03, Field Welding of Steel Water Pipe.
- .50 CSA W59-03 Welded Steel Construction.

6.2 Pipe Welding

- .1 District heating (primary) side shall be an all-welded piping system in accordance with ANSI B.31.1 and CSA B51. The building (secondary) side piping shall be a welded system in accordance with ANSI B.31.9. If grooved piping is used in the existing building secondary systems, it can be used as an acceptable alternate. However, it is strongly recommended that all risers be welded for maximum system integrity.
- .2 Welding qualifications to be in accordance with CSA B51 or ASME B31.1 section 127.5.
- .3 Qualified and licensed welders shall possess a certificate for each procedure to be performed by the authority having jurisdiction.
- .4 Registration of welding procedures shall be in accordance with CSA B51 or ASME B31.1 Section 127.5.
- .5 Submit welder's qualifications to Owner's Representative.
- .6 Joint Fit-up
 - .1 Valves welded into the system shall be open as the welding is carried out.
 - .2 The geometry of pipe weld joints (i.e. joint preparation and root opening) shall be in accordance with the tolerance specified by the weld joint sketches contained in the welding procedures submitted to the Owner's representative.
 - .3 In cases where the internal misalignment exceeds 1/16", the component with the wall extending internally shall be trimmed so that the adjoining internal surfaces are approximately flush. This trimming must not result in a piping component wall thickness less than the minimum design thickness. The change in contour shall not exceed 30 degrees
- .7 Transition, Different outside diameters
 - .1 When pipes of different outside diameters are to be welded together, either of the following two procedures shall be followed:
 - .1 Taper the outside diameter of the larger pipe by grinding or machining before welding to the outside diameter of the smaller pipe. The taper angle must not exceed 30°.
 - .2 Fill the weld joint with weld metal, flush with the outside surface of the pipe having the larger diameter. The weld metal transition between the larger and smaller pipe shall have a slope not exceeding 1:3, which may be obtained by grinding. *

6.3 Valves

- .1 Install isolating valves at all branch take-offs, at each piece of equipment and elsewhere as indicated. All primary isolation valves to be welded. Welding to valves must be done in accordance with the manufacturers' recommendations in order to prevent body distortion and to maintain tight shutoff characteristics of the valve.
- .2 Isolation Ball Valves:
 - .1 NPS 2" to 8": Working Pressure 1.6 MPa (232 psig) at 120°C, Sch. 40 Butt Weld ends to match pipe, steel body, stainless steel ball and stem, Teflon seat, reduced bore, class 300 lever actuator for valves NPS ≤6" within 2.44m (8 ft.) of floor. Provide gear operated actuator with handwheel for valves NPS ≥8" and chain wheel above 2.44m. Acceptable materials: Arinah Services – Broen Ballomax, Meridian Valves – Vexve, Armour Valve – Bohmer.

- .3 Drain and Air Vent valves:
 - .1 NPS ½" to 2": Threaded, 2000 psig WOG, ball valve, cold non-shock, 150 psig saturated steam steel body, RTFE seats and seals, blow-out proof steam design, lever handle, Acceptable material: Apollo 72-100, NIBCO T-590-CS-R-66.
- .4 Strainers:
 - .1 Install strainers at both secondary and primary side heat exchangers inlets in locations to allow easy access for removal of screen.
 - .1 NPS ≤2": Cast steel, Y-pattern, shall be flanged with stainless steel 5/32" perforated screen with 30 mesh (0.5mm), Class 300 for 1.6 Mpa (232 psig) and 120°C. Acceptable Materials: Spirax Sarco, SSI Equipment Inc
 - .2 NPS ≥2½": Cast Steel body flanged Y-pattern, stainless steel 5/32" perforated screen with 30 mesh (0.5 mm). Screen area shall be minimum three times area of inlet pipe. Class 300 for 1.6 MPa (232 psig) and 120°C. Acceptable Materials: Spirax Sarco, SSI Equipment Inc.
 - .2 Provide drain ball valve and piping to a point 400 mm from the floor. The pipe end shall be provided with a threaded forged steel cap.
 - .3 Outlets for branch connections:
 - .1 Full Size; Standard Weight, Welded tee
 - .2 One size smaller: Standard Weight, welded reducing tee, or saddle welds.
 - .3 Two or more sizes smaller;
 - .1 NPS ≤2" – Thread-o-let or reducing tee.
 - .2 NPS ≥2½" – Weld-o-let or reducing tee.

6.4 Gauges

- .1 Thermometers:
 - .1 Industrial, Bi-metal Dial, 100 -125 mm size, adjustable angle, aluminum case, 13 mm NPT stainless steel separate well, front recalibrator.
 - .2 Unit: Dual Scale °C/°F scale
 - .3 Accuracy: within ±0.5 degrees of reading.
 - .4 Range: Applicable range & span will be selected according to process conditions.
 - .5 Maximum 2 deg. per division.
 - .6 Acceptable materials: Winters, Wika, Weiss
- .2 Pressure Gauges:
 - .1 Dial type, 110 mm diameter, 304 stainless steel case and ring, phosphor bronze tube, brass or stainless-steel movement, glass or acrylic window. 13mm NPT process connection.
 - .2 Liquid filled
 - .3 Unit: Dual scale kPa/PSI
 - .4 Accuracy: within 1.0% of full scale.
 - .5 Range: 1.5 times the process system operating pressure.
 - .6 Accessories: N/A
 - .7 Acceptable materials: Winters, Wika, Weiss
- .3 Interior Piping:
 - .1 Piping
 - .1 To ASTM A53 Grade B.
 - .2 NPS ≤1 ½": Sch. 80, ERW or seamless, plain ends.
 - .3 NPS 1 ½" and over: Standard Weight, ERW or Seamless, beveled ends,
 - .2 Fittings:
 - .1 NPS ≤1 ½": Class 3000, forged steel screwed ends and socket weld ends, to ASTM A181.
 - .2 NPS ≥2": Standard Weight, forged steel, bevel ends, to A234, Grade WPB..
 - .3 Coupling, caps, plugs:
 - .1 NPS ½" to 2": Class 2000, screwed ends or socket weld ends, to ASTM A181.

-
- .4 Nipples for drains, vents, pressure gauges:
 - .1 NPS ½" to 2" : Sch. 80, screwed, to ASTM A53, Grade B.
 - .5 Unions:
 - .1 NPS ≤2": Class 3000, socket welded ends, forged steel, steel-to-steel ground joint, to ASTM A181.
 - .6 Flanges:
 - .1 NPS ≤2": Class 150 / 300, raised face, socket welded ends, to ASTM A105 and ANSI B16.5.
 - .2 NPS ≥2½": Class 150 / 300, raised face, weld neck (bored to suit pipe) to ASTM A105 and ANSI B16.5.
 - .3 Flange to match class and rating of flange supplied with equipment
 - .7 Bolts and nuts (low strength):
 - .1 NPS ≤2": bolts, carbon steel, semi-finished with heavy hex nuts, to ASTM A307, Grade B.
 - .2 NPS ≥2½": Stud bolts, carbon steel, semi-finished with heavy hex nuts, to ASTM A307, Grade B.

7.0 Inspection and Testing

.1 General

- .1 Perform examinations and tests by specialist qualified in accordance with CSA W178.1 and CSA W178.2, CGSB 48-GP-2M, and approved by Design Engineer. To ANSI/ASME Boiler and Pressure Vessels Code, Section V, CSA B51 and requirements of authority having jurisdiction.
- .2 The Design Engineer shall review and approve the contractor's pressure testing procedures at least 72 hours prior to carrying out any testing.

.2 Inspections

- .1 Unless otherwise approved by the Design Engineer, all joints in the piping systems shall remain uncovered until all tests are completed and the systems have been inspected and approved by the Engineer or Inspector.
- .2 DPS Leak Detection System assembly checks should be carried out continuously during the construction work.

.3 Hydrostatic Testing

- .1 Hydrostatic testing shall be performed in accordance with the requirements of ANSI B31.1., Owner's specifications, and the contractor's Inspection and Test Plan. Test pressure shall be 1.5 times the system design pressure.
- .2 Hydro test water shall be clean, filtered fresh or city water. There shall be no leakage in the pipeline.
- .3 All District Heating primary piping shall be hydraulically tested after installation and before painting, insulating, and concealing in any way, at a minimum test pressure of 2400 kPa for 4 hours without a drop in pressure. The secondary heating shall be hydraulically tested at 1.5 times design pressure or a minimum of 690 kPa (100 psi) as per ANSI B31.9.

- .4 Any equipment not capable of withstanding the designated test pressure shall be isolated. Flow meters, heat exchangers, and control valves are to be removed and spool pieces installed before commencing pressure tests.
- .5 The Design Engineer shall make the contractor responsible for obtaining all approvals from jurisdictional bodies for the carrying out of pressure tests on piping with joints not exposed for visual examination.

.4 Radiographic Testing

- .1 20% of all primary welds shall be radiograph tested. If any welds are shown to fail a second test will be required with radiograph of 100% of welds.

8.0 Cleaning and Flushing

- .1 The Design Engineer shall review and approve the contractor's flushing procedure.
- .2 Primary piping shall be flushed, with a chemical flush and then with potable water, to remove all foreign material from the inside of all piping to the Design Engineer's approval. Flushing velocity shall be a minimum of 1.5 m/s.
- .3 Typical acceptable system water concentrations:
 - Iron levels should be below 2 ppm.
 - Hardness should be below 2 ppm.
 - Chloride levels should be maximum 250 ppm if 316 SS Heat Exchanger plate material is used or 50 ppm for 304 SS.
 - pH level of 9.5-10
- .4 Water is to be tested by a water treatment analyst during the cleaning and flushing procedure.
- .5 The Contractor shall take all necessary precautions to prevent damage to the pipe, insulation, or structures from the cleaning operation. Flow meters, heat exchangers, and control valves are to be replaced with spool pieces.
- .6 The contractor shall install and remove all temporary piping and supports to introduce and dispose of flushing water at a safe discharge.

9.0 Commissioning

- .1 Prior to the commissioning of the DH system, both primary and secondary sides must be flushed and cleaned to the satisfaction of the Owner. The strainers shall be cleaned. Heat exchangers will only be allowed to be commissioned pending verification of the proper strainer screen and mesh have been installed at the inlets to the heat exchanger (s). The proper strainer screen/mesh sizes are as per the following:
 - .1 Braze Plate heat exchangers: 1/8" stainless steel perforated screen with 0.5mm (30) mesh.
 - .2 Plate heat exchangers: 3/64" stainless steel perforated screen.
- .2 After satisfactory water quality analysis by a qualified water treatment contractor, system start-up and commissioning may commence. A certification from the water treatment contractor will verify that the water quality is acceptable.

10.0 Accessibility

- .1 All equipment, strainers, control valves, heat exchangers, energy meters and sensors shall be installed with Space for servicing, disassembly and removal of equipment and components: provide as recommended by manufacturer or as indicated by Owner's representative.
- .2 Provide unions or flanges for ease of maintenance. Install as required. All equipment, and control valves to be provided with union or flanges for easy removal and replacement.

11.0 DES Piping Installation

- .1 The district Energy System (primary) side shall be an all-welded piping system in accordance with ANSI B.31.1 and CSA B51

12.0 Pipe Welding

- .1 Welding qualifications to be in accordance with CSA B51 and ANSI/ASME B31.1. Qualified and licensed welders shall possess a certificate for each procedure to be performed from the authority having jurisdiction.
- .2 Registration of welding procedures shall be in accordance with CSA B51 and ANSI/ASME B31.1.

13.0 Valves

- .1 Install isolating valves at all branch take-offs, and elsewhere as indicated. All primary isolation valves to be welded. Welding to valves must be done in accordance with the manufacturers' recommendations in order to prevent body distortion and to maintain tight shutoff characteristics of the valve. Valve specifications can be found under major equipment specifications.

14.0 Inspection and Testing

- .1 Perform examinations and tests by specialist qualified in accordance with CSA W178.1 and CSA W178.2, CGSB 48-GP-2M, and approved by Design Engineer. To ANSI/ASME Boiler and Pressure Vessel Code Section V: Non destructive Examination. Inspections to be performed by a Third Party testing agency.
- .2 The Design Engineer shall review and approve the contractor's pressure testing procedures at least 72 hours prior to carrying out any testing. Unless otherwise approved by the Campus Chief Engineer or TSBC Inspector, all joints in the piping systems shall remain uncovered until all tests are completed and the systems have been inspected and approved by the Campus Chief Engineer or TSBC Inspector.
- .2 DPS Leak Detection System assembly checks should be carried out continuously during the construction work.

15.0 Burying of DES Pipe prior to Pressure test (special Circumstances)

- .1 The contractor may cover (by insulating and / or burying) Central or District hot water heating piping prior to the final pressure test, provided that all of the following conditions are complied with:
 - .1 Pressure piping shall be within the scope of, and constructed to ASME B31.1 Power Piping. In addition the pressure piping shall be limited to Central or District heating piping systems only, limited to Hot Water service only where the design pressure does not exceed 1600 kPa (232 psig) and the design temperature does not exceed 120 degrees Celsius (248 degrees Fahrenheit and limited to the hydrostatic method of pressure testing only.
 - .2 Contractor shall submit and obtain registration of the piping design from Technical Safety BC prior to construction.
 - .3 specification shall include the details of how the piping shall be buried.
 - .4 The contractor shall submit and obtain acceptance of a documented pressure test procedure from Technical Safety BC, prior to conducting the pressure test. The procedure shall meet the requirements of ASME B31.1, and shall include an extended holding time for the test and include the method(s) to detect a leak.
 - .5 The Contractor shall also provide a documented procedure for the method to uncover and locate any leak that may occur during the hydrostatic testing of insulated and / or buried piping.
 - .6 Insulated and/ or buried pressure piping that shows any evidence of leakage during the pressure test shall be uncovered to the extent required to locate the leaking

- area and to effect repairs. The repairs shall meet the requirements of ASME B31.1. The repaired area shall be subject to a pressure test following completion of the repair.
- .7 Unlisted materials shall not be utilized for construction of the pressure piping unless all of the requirements of ASME B31.1 para 123.1.2 are fully complied with, prior to fabrication of the pressure piping.
 - .8 The piping to be pressure tested shall be verified by the Owner's Inspector to be constructed in compliance with BC Regulation 104 / 2004, CSA B51 Boiler, Pressure Vessel and Pressure Piping Code, ASME 831.1 Power Piping Code, the owners specification, and the registered design prior to the pressure test.
 - .9 Upon completion of a successful pressure test, a Construction Data Report for Piping Systems Constructed Inside British Columbia (form 1329) shall be completed and executed as follows:
 - .1 Signed and dated under the Certificate of Compliance by a licensed Contractor, and
 - .2 Signed and dated under Certificate of Inspection section by the Owners Representative and by a Safety Officer employed by TSBC , subsequent to a successful completion of the hydrostatic pressure test
 - .3 A copy of the report shall be submitted to Technical Safety BC
 - .2 The Contractor shall document the criteria that must be met prior to covering the pressure piping by any means (including by insulation and / or burying). The criteria shall include but not limited to:
 - .1 The Contractor shall provide free access to the designated Owners Inspectors and to a Safety Officer to perform any inspections deemed necessary, prior to covering the pressure piping.
 - .2 The Contractor shall notify and obtain prior acceptance of a Safety Officer prior to covering the piping.
 - .3 iii. The piping shall be constructed in compliance with the design, material, fabrication, assembly, examination and testing requirements of the ASME 831.1, and shall be constructed in accordance with the design that has been registered with TSBC.
 - .4 All fabrication, assembly, erection activities and non-destructive examinations required by ASME B31.1 Table 136.4 (including visual weld inspection), and any required repairs, shall be completed prior to the final pressure test
 - .5 A Safety Officer may request any pressure piping be uncovered, at any time and the contractor shall comply with such a request.

16.0 Hydrostatic Testing

- .1 Hydrostatic testing shall be performed in accordance with the requirements of ANSI B31.1., Owner's specifications, and the contractor's Inspection and Test Plan.
- .2 Test pressure shall be 1.5 times the system design pressure. Hydro test water shall be clean, filtered fresh or city water. There shall be no leakage in the pipeline.
- .3 All District Heating primary piping shall be hydraulically tested after installation and before painting, insulating, and concealing in any way, at a minimum test pressure of 2400 kPa for 4 hours without a drop in pressure.
- .4 Any equipment not capable of withstanding the designated test pressure shall be isolated. Flow meters, heat exchangers, and control valves are to be removed and spool pieces installed before commencing pressure tests.
- .5 The Design Engineer shall make the contractor responsible for obtaining all approvals from jurisdictional bodies for the carrying out of pressure tests on all piping with joints and visual examination as per B31.1.

17.0 Radiographic Testing

- .1 100% of all primary buried welds shall be radiograph tested.
- .2 20% of all primary non buried welds shall be radiograph tested. If any welds are shown to fail a second test will be required with radiograph of 100% of welds.

18.0 Cleaning and Flushing

- .1 The Design Engineer and Campus Chief Engineer shall review and approve the contractor's flushing procedure.
- .2 Primary piping shall be flushed, with a chemical flush and then with potable water, to remove all foreign material from the inside of all piping to the Design Engineer's approval. Flushing velocity shall be a minimum of 1.5 m/s.
- .3 Typical acceptable system water concentrations:
 - Iron levels should be below 2 ppm.
 - Hardness should be below 2 ppm.
 - Chloride levels should be maximum 250 ppm if 316 SS Heat Exchanger plate material is used or 50 ppm for 304 SS.
 - pH level of 9.5-10
- .4 Water is to be tested by a water treatment analyst during the cleaning and flushing procedure.
- .5 The Contractor shall take all necessary precautions to prevent damage to the pipe, insulation, or structures from the cleaning operation. Flow meters, heat exchangers, and control valves are to be replaced with spool pieces.
- .6 The contractor shall install and remove all temporary piping and supports to introduce and dispose of flushing water at a safe discharge.

19.0 Commissioning

- .1 Prior to the commissioning of the DES system, the system must be flushed and cleaned to the satisfaction of the Owner.
- .2 After satisfactory water quality analysis by a qualified water treatment contractor, system start-up and commissioning may commence. A certification from the water treatment contractor will verify that the water quality is acceptable.

20.0 Accessibility

- .1 All buried valves shall have a 10" valve box with cast lid. Lid to be have the identification letters DES permanently etched on with welded letters. Valve boxes in brick shall be square with a round lid. Acceptable materials: Dobney Foundry MR10-18B or equivalent.





Most Common installation



Installation in Brick

21.0 Chemical Addition

- .1 Contractors are required to add the appropriate quantity of chemical to the district piping to prevent corrosion. The Chemical type to be used must be confirmed prior to introducing to the system to prevent adverse effects of mixing chemicals. Alternative options are available providing prior arrangements have been made with Campus Chief Engineer.

*****END OF SECTION*****

1.0 **GENERAL**

1.1 **System Description**

- .1 There are few buildings left serviced by steam and those are serviced by steam from the Bio Energy Research and Demonstration Facility. Saturated steam is generated at 827 kPa (120 psig) for distribution to the remaining steam line running north lower mall and east up University Blvd.
- .2 There is a condensate return as part of UBC's steam distribution system. Wherever the term "steam distribution" is used, it applies to both steam supply and condensate return piping and appurtenances unless otherwise specified.
- .3 Most of the steam/condensate system is gradually being replaced by a District Energy Hot Water system. Also see Division 23, Section 23 21 05 District Hot Water Heating System.

2.0 **MATERIALS AND DESIGN REQUIREMENTS**

2.1 **Responsibilities**

- .1 UBC Energy & Water Services (EWS) is primarily responsible for operation, maintenance, and overall stewardship of the steam distribution system. The demarcation of UBC Energy & Water Services point of service is normally up to and including the PRV at each consumer. Energy & Water Services also maintain the condensate tank and pumps, whereas the steam distribution with the consumer's premises is outside EWS jurisdiction. Also refer to Condensate Pump and Tank Standard Drawing located on web page (https://technicalguidelines.ubc.ca/technical/divisional_specs.html) under Division 33's section listings.
- .2 Key positions in UBC Energy & Water Services are described in Division 33, Section 33 00 10 Underground Utilities Services of UBC Technical Guidelines.
- .3 Unless otherwise agreed in writing, the project Designer is responsible for all design, permit, and inspection requirements of Technical Safety BC (TSBC).
- .4 The project Designer must incorporate all specific requirements for metering, design and materials and execution of this section into the contract drawings in the form of job-specific notes. Only making reference to UBC Technical Guidelines in the drawings is not sufficient.

2.2 **Steam Distribution Standards and Policies**

- .1 The latest revisions of the following standards and policies shall apply to steam distribution at UBC:
 - .1 B.C. Boiler and Pressure Vessel Act and ASME B31.1 Power Piping Code; TSBC.
 - .2 UBC Sustainability Development Policy #5 (<https://universitycounsel.ubc.ca/board-of-governors-policies-procedures-rules-and-guidelines/policies/>).
 - .3 CSA standards as applicable.

2.3 Steam Distribution Service Connections

- .1 The first step to install any new or substantially modified connections to the steam distribution system at UBC is complete a Utility Service Connection Application. This and other forms can be found at <https://energy.ubc.ca/community-services/contractors-developers/>.
- .2 Any new connections to the steam distribution system will be reviewed for consistency with UBC Energy & Water Services standards as defined in the UBC Technical Guidelines. If necessary the steam distribution engineering/flow model will be updated and run by UBC Energy & Water Services at no cost to the project.
- .3 The Designer shall obtain the Steam service records by contacting the Records Clerk at Infrastructure Development, Records Section (Telephone: 604-822-9570) and develop proposed service connection location(s).

2.4 Steam Distribution Design and Materials

- .1 Steam Piping
 - .1 Maximum operating pressure shall be 1,030 kPa (150 psig), A106 Grade B seamless.
 - .2 Schedule 40 is required for pipe sizes over 2", and Schedule 80 is required for pipe sizes 2" and smaller.
 - .3 Fittings shall be A234 WPB, Schedule 40 for pipe sizes over 2", and #3000 forged-steel, socket welded for pipes 2" and smaller.
 - .4 Flanges shall be #150 raised-face, weld neck (bore to suit pipe), A105, Grade 1.
 - .5 Pressure bolting shall be A194, Grade B7.
 - .6 Support lugs shall be carbon steel.
 - .7 No cast iron or copper based metal fittings or valves are acceptable.
 - .8 All valves upstream of PRV's, including PRV bypass valve, shall be at least #150 rated and socket welded for pipe sizes 2" and smaller. Greater than 2" shall be flanged or butt welded.
 - .9 Attachment to condensate main piping shall be a tee. Optionally a Sockolet™ shall be used for pipes 2" or smaller, or Weldolet™ if greater than 2".
- .2 Condensate Piping
 - .1 Maximum operating pressure shall be 1,030 kPa (150 psig), A106 Grade B seamless. Design temperature must be a minimum of 200C (400° F).
 - .2 Schedule 80 is required for all pipe sizes in consideration of corrosion.
 - .3 Fittings shall be A234, WPB and #3000 F/S socket welded for pipes 2" and smaller.
 - .4 Flanges shall be #150 raised-face, weld neck, extra heavy (XH) A105, Grade 1.
 - .5 Pressure bolting shall be A194, Grade B7.
 - .6 Support lugs shall be carbon steel.
 - .7 No cast iron or copper based metal fittings or valves are acceptable.
 - .8 Beginning with the last condensate return valve leaving a building, all valves shall be at least #150 rated and socket welded for pipe sizes 2" and smaller. Greater than 2" shall be flanged or butt welded.
 - .9 Attachment to condensate main piping shall be a tee. Optionally a Sockolet™ shall be used for pipes 2" or smaller, or Weldolet™ if greater than 2".
- .3 Isolating valves are required in all mains and branches (incoming and outgoing) for steam and condensate.
- .4 Double block and bleed is mandatory inside steam manholes on all main steam, main condensate, and small bore piping (including steam traps).

- .5 Steam meters are required for all newly construction or substantially modified buildings at UBC. Steam meters shall be installed inside buildings, and located upstream of the pressure reducing valves (PRV). For core buildings use Endress & Hauser and for billable buildings use Foxboro. Refer to Standard Documents – 1130-UT-05-SteamMeterStd-Foxboro.dwg and 1130-UT-SteamMeterStd-Endress.dwg, the locations of which are referenced in section 2.1.1 above. As indicated on the drawing standard, the meter, computer, and transmitter are to be procured and supplied by UBC Energy & Water Services. The project will provide a purchase order for Energy & Water Services to purchase the meter hardware. There will be no additional markup or procurement fees.
- .6 Condensate return shall be a pumped, open system and shall conform to UBC's condensate pump system standard - refer to Standard Documents - CondPumpStd.pdf.
- .7 A copy of design approval by TSBC shall be provided to UBC Energy & Water Services Manager, Mechanical Utilities (Senior Mechanical Engineer) and Campus Chief Engineer.
- .8 A copy of hydrostatic tests required by TSBC shall be provided to UBC Energy & Water Services Manager, Mechanical Utilities and Campus Chief Engineer.
- .9 Manholes shall be constructed with one or two side openable tops.
- .10 Insulation of piping, valves and expansion joints shall conform to UBC Energy & Water Services requirements (available upon request submitted to UBC Energy & Water Services).
- .11 All underground steam and condensate piping shall be installed in inverted concrete channel with removable lid, all joints sealed with tar. Perforated cast iron drainpipe, connected to the storm sewer shall be installed under all steam distribution trenches.
- .12 Steam trap assemblies inside steam manholes shall conform to UBC Energy & Water Services Standard. Refer to Standard Documents - SteamTrapStd.pdf.
- .13 Welding: procedures and welder certification as per ASME B31.1 applies to all steam and condensate piping, equipment, and pipe supports. There shall be no splatter, arc strikes, or center punch marks on piping.
- .14 Zinc coated components shall not be in contact (welded, bolted, or loose) with any part of the piping.
- .15 Substances containing chlorine or which will decompose to hydrogen chloride (i.e. coating to prevent adhesion of weld splatter) shall not be applied to any part of the piping.

3.0 EXECUTION REQUIREMENTS

- .1 Minimum soil cover to be 700 mm.
- .2 Minimum 750 mm horizontal clearance required from all other services, except for condensate.
- .3 Cross electrical duct-bank above and leave vertical space for any future expansion. Crossing angle shall be 90° degree. If future expansion is not required, leave minimum 200 mm vertical clearance from the top of electrical duct-bank and place minimum 50 mm Temperlite overlapping minimum 250 mm on each side.
- .4 The insulation of piping, valves and expansion joints shall conform to these requirements:

- .1 Steam pipes to be insulated with 2" thick "Temperlite"* , c/w minimum 0.016" thick corrugated aluminum jacketing.
- .2 Condensate pipes to be insulated with 1-1/2" thick "Temperlite", c/w minimum 0.016" thick corrugated aluminum jacketing.
- .3 "Temperlite" insulation should stop minimum 2" before any flange joint to allow easy removal of bolts/nuts. Where the insulation stops, it should be tapered at 45° angle and clad with smooth aluminum end caps.
- .4 All valves and expansion joints should be insulated with removable heat jackets fabricated from 1" thick "Fibrox" mat on stainless steel mesh, covered with #1702 silicone cloth. Each heat jacket should cover at least 2" of adjacent "Temperlite" insulation on both sides of the valves or the expansion joint.
- .5 Pipe-covering protection saddles shall be used for high temperature service ($\geq 50^{\circ} \text{C}$), Model Grinnell Fig. 161 or equal.
- .6 On completion of the job, the surface temperature is to be inspected in six locations with a heat gun and records provided to Mechanical Utilities Engineer.

* UBC Energy & Water Services may consider alternative insulating material with similar or better properties.

- .5 When steam pipes are not installed in concrete channel, use pipe bedding and backfilling as follows:
 - .1 For pipe bedding use clean granular pipe bedding, graded gravel, 19 mm(-), MMS type 1:
 - .1 Bottom thickness shall be a quarter of pipe diameter but minimum 100 mm.
 - .2 Top shall be minimum 300 mm.
 - .3 Sides shall be minimum 225 mm to maximum 300 mm.
 - .2 For trench backfill, native backfill may be used if free of rock greater than 100 mm.
- .6 Shutdowns must be requested in writing adhering to UBC's campus-wide shutdowns procedures. Refer to Service Shutdown Request at <https://buildingoperations.ubc.ca/resources/policies-procedures-forms/>.
- .7 Operating valves on the steam-condensate distribution system shall only be performed by UBC Energy & Water Services.

*****END OF SECTION*****

1.0 **GENERAL**

1.1 **Related UBC Guideline**

- .1 Division 26 through 33

1.2 **Coordination Requirements**

- .1 UBC Energy and Water Services
- .2 UBC Building Operations

1.3 **Power**

- .1 The University owns and operates the power system consisting of 60 KV underground and overhead distributions, and 12 KV underground distributions.
- .2 The University purchases power in bulk form from BC Hydro. The two 60 KV lines feed two substations, one located on the South Campus and one on the Main Campus.
- .3 The Main Substation supplies in turn a 12 KV indoor switching station.
- .4 The 12 KV systems is distributed underground in a combined duct and manhole system which services throughout the major portion of the North Campus and a portion of the South Campus.
- .5 The 12 KV system is nominally rated at 12,480 volts, 3 phase, 3 wires, Wye System low resistance grounded.
- .6 The design limits shall be basic impulse level 95 KV and design fault 300 MVA symmetrical.
- .7 The power distribution is a Dual Radial System with 500 MCM low resistive grounded single conductor crosslink polyethylene for 12 KV system.
- .8 For a General Distribution Diagram of the 12 KV feeders, refer to Division 26, Standard Drawing E1-1 (https://technicalguidelines.ubc.ca/technical/divisional_specs.html). Also, refer to 5.4.3.1 Design Development Brief.

1.4 **Communication**

- .1 The Campus communication systems in most areas of the campus is owned and operated by the University. Project requirements shall be coordinated between the User, the Consultant and the Cable Facilities Services by the Project Manager.

1.5 **Central Building Alarm – A Division, Building Operations, UBC**

- .1 The University operates a Building Management System (BMS) to provide control and alarm monitoring for all primary mechanical and electrical systems.
- .2 The panels are usually located in the building mechanical rooms to capture the necessary alarm event. This event is transmitted across the BMS network to the appropriate display terminals.

1.6 **UBC Standard Forms**

- .1 The following standard forms apply to all utilities for this project, as applicable:

- .1 UBC Application for Service Shutdown.
- .2 UBC Application for Service Connection.
- .3 I-B-07 - Clearance Permits.
- .4 I-B-33 - Test and Work Permits.
- .5 UBC Utilities Manhole Entry Permit 1.

*****END OF SECTION*****

1.0 **GENERAL**

1.1 **Related UBC Guidelines**

- .1 Section 33 71 00 Electrical Utility Transmission and Distribution

1.2 **Coordination Requirements**

- .1 UBC Energy & Water Services
- .2 UBC Building Operations

1.3 **Description**

- .1 UBC requirements for Duct Banks and Manholes.

2.0 **MATERIALS AND DESIGN REQUIREMENTS**

2.1 **Design Standards**

- .1 Work shall comply with requirements of:
 - .1 WorkSafe BC.
 - .2 BC Safety Authority.
- .2 All civil work including duct banks, manholes and cast-in-place and precast concrete shall comply with UBC Technical Guidelines, BC Hydro Standards, or Master Municipal Construction Documents (MMCD) as applicable.

2.2 **Trenching**

- .1 Prior to any trenching the duct runs shall be surveyed and staked out. Approval of the staked runs shall be obtained from the Consultant.
- .2 All trenching, excavating, and backfill shall be done to MMCD specifications. Backfill and bedding materials shall be supplied by the Contractor. Trench bottom shall be continuous, firm and shall provide uniform support to the ducts.
- .3 Backfill materials shall be free of rocks larger than 75mm diameter, wood, cinders, ash, and frozen materials. Top surface shall be landscaped to match the existing ground and any road surfaces shall be made good to match existing conditions.

2.3 **Other Services**

- .1 There are existing services and may be additional runs of other services such as electrical, telephone, water, sewers, gas, oil, drainage, etc. Exercise the maximum care to avoid interference or damages to these. Refer to Underground Utility Services.

2.4 **Requirements for Ducts**

- .1 Ducts shall be rigid PVC, encased burial type duct conforming to the specific of CSA standard C22.2 No. 211.1 "Rigid Types EB1 and DB2 / ES2 PVC Conduit". Ducts shall be 125mm (5") for all ducts between manholes.

- .2 Ducts shall be:
 - .1 Power services: minimum: 6 – 125 mm (5") between manholes and 4 – 100 mm (4") into buildings. Larger size may be required by CSA or UBC Energy & Water Services.
 - .2 Communication services: minimum 4 - 125 mm (5") between manholes and 4 -100 mm (4") into buildings.
- .3 Ducts shall be sized on the drawings.
- .4 Ducts shall be buried at a minimum depth of 900 mm. Duct runs shall be evenly sloped toward duct terminations for drainage.
- .5 Ducts shall terminate with bell mouth ends.
- .6 All duct bends shall be long sweep "Utility" bends manufactured to utility pulling specifications.

2.5 Requirements for Manholes

- .1 Manholes shall be 1830 mm x 3300 mm x 2000 mm high inside dimensions or as specified by UBC Energy & Water Services.
- .2 Manhole shall be complete with cast manhole cover, frame and brick assembly between manhole and manhole lid.
- .3 Materials shall include:
 - .1 Pre-cast Manhole Assembly.
 - .2 Manhole Frame.
 - .3 Manhole Cover.
 - .4 Spacer Rings.
 - .5 Pulling Irons.
 - .6 Ground Rods.
 - .7 Sump Cover.
- .4 Manholes shall be constructed to the following UBC Utility Standards:
 - .1 E 3-1 Standard Electrical Precast Manhole.
 - .2 E 3-2 Standard Electrical Manhole Pour in Place.
 - .3 E 3-3 Additional Reinforcing for Pour in Place Electrical Manhole.
 - .4 E 3-4 Standard Electrical Manhole Cover & Riser Details.
 - .5 E 3-5 Standard Electrical Manhole Sump Detail.
 - .6 E 3-6 Typical Manhole Grounding & Details.
 - .7 E 3-7 Typical Manhole Separation.
- .5 Pre-cast Manhole using BC Hydro 4212 Chamber may be substituted as an alternate.
- .6 Concrete shall not be placed in foundations until the soil breaking has been reviewed by the Engineer.
- .7 All manholes shall have a sump with positive drainage. Manhole drains shall be connected to the storm water system.
- .8 Testing costs for compaction and concrete tests shall be paid for by the project.

2.6 Requirements for Concrete Encased Duct Bank

- .1 All Service Ducts shall be concrete encased.
- .2 All Civil Work associated with Duct Banks shall be to BC Hydro and MMCD Specifications.
- .3 Duct Banks shall be constructed in accordance with UBC Standards Drawings:
 - .1 E2-1 Standard Concrete encased Electrical Duct.
 - .2 E2-3 Standard Electrical Duct Bank.
 - .3 E2-4 Electrical Ductbank Clearances to Steam Distribution Lines.
- .4 Forms must be used on the walls of the duct bank.
- .5 Duct connectors shall be staggered so they are never adjacent to another coupling. Manufactured intermediate spacers shall be used throughout the length of the duct run every 2 meters.
- .6 Concrete shall have maximum 200 mm (3/4") aggregate, minimum 20 MPA strength at 28 days, and shall contain "Anti-Hydro" mixed as recommended by the additive Manufacturer.
- .7 Immediately after installation, ducts shall be tested for blockages and cleaned as necessary. Prior to completion the ducts shall be swabbed and mandrel led.
 - .1 The civil contractor shall ensure the quality of installation of all ducts by passing a mandrel or test slug sized not less than indicated in the table below and through the entire length of all installed conduits and in both directions:

Duct Diameter (mm)	Mandrel Diameter min. (mm)
75	69
100	91
125	114

- .2 The civil contractor shall provide written verification of mandrel tests to UBC Energy & Water Services upon successful completion.
- .3 The civil contractor shall identify and remediate any portions of installed ducts that do not easily permit passage of the mandrel or test slug.
- .8 A 10 mm (1/4") pulling line shall be installed in all ducts.

2.7 Requirements for Warning Tape During Construction

- .1 During construction a warning tape (yellow) imprinted "CAUTION BURIED ELECTRICAL LINE" shall be installed at all duct banks and buried conduit.
- .2 Warning tape shall be laid in the trench midway between duct bank and finished grade.

END OF SECTION

1.0 **GENERAL**

This section refers to the works that are unique to the requirements for inspecting new and existing sanitary and storm pipes and pipe culverts by closed circuit television. This section must be referenced to and interpreted simultaneously with all other sections pertinent to the works described herein.

1.1 **Related Sections**

- .1 Section 33 00 10 Underground Utilities Services
- .2 Traffic Regulation "Traffic Control Manual for Works on Roadways" (second edition), published by MoT.
- .3 Section 33 01 30.41 Cleaning of Sewers

1.2 **References**

- .1 These specifications must be referenced to and interpreted simultaneously with all other Standards and Specifications pertinent to the works described herein.
- .2 Reference standards, specification or publications:
 - .1 Water Research Centre (WRc) publication Manual of Sewer Condition Classification (MSCC), Third Edition, 1993 including Addendum - February 1996.
 - .2 NAAPI Manual of Sewer Condition Classification, Second Edition, 2007.
- .3 Nomenclature
 - .1 CCTV Closed Circuit Television
 - .2 JPEG Joint Photographic Experts Group
 - .3 MPEG Movie Photographic Experts Group
 - .4 S-VHS Super VHS format video
 - .5 DVD Digital Video Disk
 - .6 MSCC Manual of Sewer Condition Classification (WRc. – 3rd edition)

1.3 **Submission of Certification**

- .1 Submit a copy of the CCTV operator's current NAAPI certification certificate to the Contract Administrator at least one week prior to the start of the CCTV inspection operations.
- .2 Submit copies of certificates for each CCTV operator working on the contract.

1.4 **Work Regulations**

- .1 Work shall conform to all applicable regulations of WorkSafe BC. The Contractor shall confirm training compliance in the following:
 - .1 Confined space entry
 - .2 Ventilation
 - .3 Atmospheric monitoring
 - .4 Personal protective equipment
- .2 The Contractor shall provide dates of confined space training completion for each worker and a list of equipment required for confined space entry.

1.5 **Scheduling of Work**

- .1 Schedule work to minimize interruptions to existing services.

- .2 Maintain existing flow during inspection survey unless flow reduction measures required (see Clause 3.11).

1.6 Measurement for Payment

- .1 All units of measurement for payment will be as specified herein unless shown otherwise in Form of Tender
- .2 CCTV pipeline inspection will be measured in lineal metres. Payment will be made at the unit price bid in Form of Tender.
- .3 Measurement will be determined by calibrated electronic measure along the sewer from the inside wall of manhole to inside wall of manhole or end to end of sewer pipe for all sections except where a blockage or obstruction occurs.
- .4 For sections of pipe where a blockage or obstruction occurs, measurement will be from the start of inspection (inside wall of manhole) to the point of abandonment of survey.
- .5 For sections of pipe with the WRc. condition code CU (camera underwater) that has a continuous distance greater than five (5) metres, the measurement above will be reduced by the distance in excess of the five metres.
- .6 Bypass pumping for each situation as described in the Form of Tender will be made as lump sum.

2.0 PRODUCTS

2.1 Equipment

- .1 A Survey Vehicle, containing a separate area for viewing, recording and controlling of the CCTV operation is required as follows:
 - .1 Viewing and control area to be insulated against noise and extremes in temperature. External and internal sources of light to be controlled to ensure the light does not impede the view of the monitor screen. Proper seating accommodation shall be provided to enable one person, in addition to the operator, to clearly view the monitor screen.
 - .2 All equipment utilized within the pipeline shall be stored outside the viewing, recording and control area.
 - .3 Vehicle to be equipped with a telephone for communication with the Engineer for the duration of the work.
 - .4 Electrical power for the system to be self-contained. External power sources from public or private sources will not be permitted.
- .2 Survey Equipment shall have sufficient cables to view the lengths of pipe as specified.
 - .1 Survey unit shall be a self-propelled crawler type with a means of transporting the CCTV camera in a stable condition through the pipeline.
 - .2 Each unit shall carry sufficient numbers of guides and rollers such that, when surveying, all cables are supported away from pipe and manhole edges. All CCTV cables and lines used to measure the camera's location within the pipeline shall be maintained in a taut manner and set at right angles, where possible, to run through or over the measuring equipment.
 - .3 Each unit shall interface with a data generator and appropriate software to record the alpha-numeric data associated with the pipeline condition and header reference location information.

- .3 The camera shall be capable of producing high quality colour imagery and provide complete inspections and view of all laterals and deficiencies.
 - .1 The camera shall be a "Pan & Tilt" type having the capability of panning the pipe at 360° and tilt capability of 270°.
 - .2 The camera shall be equipped with an inclinometer to record the slope of inspected pipe.
 - .3 The live picture is to be visible with no interference and capable of registering a minimum of 360 lines of resolution at the periphery.
 - .4 Focus and iris adjustment shall allow optimum picture quality to be achieved and to be remotely adjusted. The adjustment of focus and iris shall provide a focal range from 150mm in front of the camera's lens to infinity. The distance along the sewer in focus from the initial point of observation shall be a minimum of twice the vertical height of the sewer.
 - .5 The camera is to be waterproof with a self-contained lighting system capable of being remotely adjusted. Lights shall provide an even distribution of light around the pipeline perimeter without the loss of contrast or flare out or picture shadowing.

2.2 Materials

- .1 Digital video files are to be stored on new, unused DVD-R media in MPEG 2 format.
- .2 Photographs are to be in colour, with a minimum image size of 90mm x 70mm and shall be reproduced on premium glossy photo quality paper.

3.0 EXECUTION

3.1 CCTV Inspection

- .1 The Contractor shall submit samples of inspection reports, video (in MPEG 2 DVD format) together with corresponding digital data files for the Owners review within one week of receipt of notice to proceed with contract. This submission shall demonstrate compliance with the contract specifications and the accepted submission will be used as a benchmark for subsequent inspection report submissions.
- .2 No inspection surveys are to be carried out under this contract until an acceptable sample inspection report has been approved by the Contract Administrator.
- .3 Flow in the pipeline is not to exceed approximately 1/3 of the pipe diameter. Notify of excessive flows, inspect using flow reduction method (See Clause 3.10).
- .4 Steaming and fogging encountered during the inspection survey shall be eliminated by introducing forced air flow by means of fan.
- .5 The camera lens is to remain free of grease or other deleterious matter to ensure optimal clarity.
- .6 Inspection video images are to be produced in MPEG2 format by the following method:
 - .1 Video capture card and software designed to create and store real-time MPEG2 digital file direct to computer hard drive.
 - .2 Create a separate digital file and a separate title for each individual manhole-to-manhole inspection report. Format for the video file numbering to be provided by the Contract Administrator.
- .7 Set zero chainage at face of every manhole, or on entrance into pipe or start of pipe culvert.

- .8 Report and record on the full length of pipeline from inside face to inside face between manholes or outlet end of pipes and from one end of the pipe culvert to the other.
- .9 Note condition of pipe joints at manhole walls at the beginning and end of each pipeline.
- .10 The data generator shall electronically generate, and clearly display on the viewing monitor and video recording, a record of the following minimum information prior to the start of each run:
 - .1 Manhole (from-to) / pipe length reference numbers.
 - .2 Pipeline dimensions
 - .3 Pipe material (i.e. vitrified clay, concrete, pvc etc.)
 - .4 Type or use of pipe (i.e. sanitary or storm sewer)
 - .5 Date of survey (yyyy.mm.dd)
 - .6 Road name/location
 - .7 Direction of travel of survey equipment (U or D, Upstream or Downstream)
 - .8 Inspection (report) number. Format to be provided by the Contract Administrator.
 - .9 Verbal description of all the above on screen information.
- .10 The data generator shall continuously electronically generate, and clearly display on the viewing monitor and video recording, a record of the following minimum information during each run:
 - .1 Automatic update of the camera's metre reading position from adjusted zero.
 - .2 Manhole/pipe length reference numbers.
 - .3 Type or use of pipe (i.e. sanitary or storm sewer)
 - .4 The unique inspection/report number of the run.
 - .5 Display digital information such that it will not interfere with the video image on the screen.
- .11 The camera must stop at each defect, change of condition of pipe and service connection to record defect in accordance with WRc codes.
- .12 Pan each service connection (junction) such that the camera looks down the centerline of the service, pause for a minimum of five (5) seconds and note condition of the joint and /or pipe/service interface.
- .13 Immediately notify Contract Administrator of any blockage or obstruction that will not allow passage of survey equipment.
- .14 Restart the inspection survey from the opposite end of pipeline or culvert when a blockage or obstruction is encountered unless directed by Contract Administrator.

3.2 Site Coding Sheets

- .1 Each pipeline length to be recorded according to the WRc, MSCC 3rd edition. Any variation from the manual is to be noted in the survey report.
- .2 Standard coding form shown on page 14 of MSCC to be modified as follows:
 - .1 Line 2, field 8 (date) to be eight (8) characters in the format of yyyy.mm.dd (year, month, day).
 - .2 Condition detail number (video count) to be six (6) characters in the format of hh.mm.ss (hours, minutes, seconds).
 - .3 Note observations as to condition of service connections beyond mainline in remarks column using standard codes as per MSCC.

3.3 Camera Position

- .1 Position the camera lens centrally in the pipeline to a tolerance of $\pm 10\%$ off the vertical centerline axis of the pipeline. For elliptical pipe the camera to be positioned 2/3 the height of the pipe measured from the invert.

- .2 Position the camera lens looking along the longitudinal axis of pipeline except when viewing service connections or panning defects.

3.4 Camera Travel Speed

- .1 Travelling speeds of the camera in the pipeline shall be as follows:
 - .1 0.1m/s for pipeline of diameter less than 200mm.
 - .2 0.15 m/s for diameters 200mm and larger but not exceeding 310 mm: and
 - .3 0.20 m/s for diameters exceeding 310 mm

3.5 Camera Position Chainage Device

- .1 Use a chainage device which enables the cable length to be accurately measured to indicate the location of the camera.
 - .1 Chainage information to be transmitted electronically to control area and displayed on the monitor.
- .2 Chainage device shall be accurate to within 0.3 m up to the first 50 m of pipe length and within $\pm 1\%$ for lengths exceeding 50 m.
- .3 Chainage tolerance shall be checked at the start of contract and a minimum of once every two weeks there after or every 5000 m of pipeline inspected, whichever is greater.
- .4 Provide an audit form showing dates and distances checked to meet both tolerance requirements. Chainage linear measurement to be checked by use of a cable calibration device or tape or electronic measurement between fixed points.

3.6 Photographs and/or Digital Images

- .1 Photograph all major defects as defined by condition codes: B, CM, CXI, D, FC, FL, FM, H, IR, IG, JDL, JX, OB, OJL, RM, and X.
- .2 The following data, in alpha-numeric form, shall be overlaid on photographs such that it will not interfere with the defect condition reported:
 - .1 Report/job number
 - .2 Metre reading position (chainage)
 - .3 Manhole/pipe length reference numbers (from - to)
 - .4 Photograph number
 - .5 WRc. condition defect code
 - .6 Date of survey (yyyy.mm.dd)
- .3 Capture photographs and alpha-numeric data as a digital image in JPEG format if required, as specified in contract documents.
- .4 Co-ordinate photographs with the hard-copy report by reference number and inserting into the report following the relevant section of pipeline inspected.

3.7 Inspection Reporting Hard copies & Digital Format

- .1 Submit reports to the Contract Administrator within 10 working days of completion of the field work on a continuous basis as the inspection area or pipeline types are finalized.
- .2 Present machine printed (hard copy) and computer generated database reports according to the MSCC format as follows:

- .1 Each binder to commence with an index of all survey inspection reports contained within.
 - .2 Hard copy reports to be presented in tabular form in accordance with WRc MSCC
 - .3 Reports to be presented in sections or drainage areas and/or by pipeline type or as specified in the contract documents.
 - .4 Computer database file to contain identical survey report information as the printed report exclusive of photographs.
 - .5 Digital information to be presented in tabular configuration in accordance with the UBC standard file format in Microsoft ACCESS (.MDB) (See Clause 3.12). A single master database file to be presented at the end of the project containing all the project CCTV reports.
 - .6 Provide a CD ROM of digital photographs. Each disk to be labelled with photo and contract numbers.
 - .7 Include Owner supplied, scale drawings showing highlight inspected pipeline. Drawing to be attached to inspection condition report for each section of sewer pipeline surveyed.
- .3 Present reports in 215 mm x 280 mm three ring (D type) binders.
 - .4 Attach computer disks (DVD and CD) in three hole plastic diskette sheet holder in back of binder.
 - .5 Attach identical identification labels on the three ring binder, DVD's (video files) and CD's (database and still digital images).
 - .6 Provide additional copies of printed reports, if required, or as specified in contract documents.
 - .7 All dimensions and chainages in the reports shall be in metric units.

3.8 Flushing and Cleaning

- .1 Clean or flush sewers immediately prior to CCTV inspection survey, unless otherwise specified in the contract documents or directed by the Contract Administrator.

3.9 Root Cutting and Removal

- .1 Remove roots for condition codes RM where required, to allow for CCTV equipment to pass.

3.10 Flow Reduction

- .1 Reduce flow in pipeline to approximately 1/4 pipe diameter to allow CCTV inspection by combination of the following:
 - .2 Schedule work for off peak flow times.
 - .3 Plug or block flow at upstream manhole.
 - .1 Plug designed to either plug all flow or impede flow to the approximate 1/4 pipe diameter.
 - .2 Obtain Contract administrator's approval prior to plugging or impeding any flow.
 - .3 Remove plug or blocks to slowly return flow to normal without surge or surcharging downstream pipeline.
- .4 Temporary bypass pump flow around inspection section when required, as specified in contract documents. Plug to be flow through with hoses and pump of sufficient capacity to handle the peak flow. Hoses and couplings to be leak free. Flow to be pumped to downstream manhole on same system or run as inspection is to take place. Obtain Contract Administrator's approval prior to setting up temporary bypass pump system.

3.11 Coding Accuracy

- .1 Coding accuracy shall be a function of the number of defects or construction features not recorded (omissions) and the correctness of the coding and classification recorded. Coding accuracy to satisfy the following requirements:
 - .1 header accuracy 95%
 - .2 detail accuracy 85%
- .2 The Contractor shall implement a formal coding accuracy verification system at the onset of the work. Coding accuracy to be verified by the Contractor on a random basis on a minimum of 10% of the inspection reports. Contract Administrator will be entitled to review the accuracy verification system and results and be present when the assessments are being conducted.
- .3 A minimum of two accuracy verifications shall be performed for each operator for each working week. Coding not satisfying the accuracy requirements shall be re-coded and the accuracy of the inspection report immediately preceding and following the non-compliant inspection shall be verified. The process shall be repeated until the proceeding and subsequent inspections meet accuracy requirements.

3.12 Standard CCTV Digital File Format – Header Table

- .1 Below are two tables listing fields and data types to be used in the Digital file (MDB) submission.

HEADER TABLE

NAAPI FIELD NAME	DATA TYPE	FIELD PROPERTIES		CITY OF FIELD NAME
ID	AutoNumber			
SURVEYEDBY	Text	12		
CONTRACTNUMBER	Text	8		
JOBNUMBER	Text	10		
CATCHMENT	Text	10		
DIVISION	Number	Byte		
DISTRICT	Text	3		
PIPELENGTHREF	Text	11		
DATE	Date/Time			
TIME	Date/Time			
LOCATION	Text	50		
STARTMANHOLE	Text	10		
SDEPTH	Text	4		
SCOVER	Number	Single		
SINVERT	Number	Single		
FINISHMANHOLE	Text	10		
FDEPTH	Text	4		
FCOVER	Number	Single		
FINVERT	Number	Single		
USESEWER	Text	1		
DIRECTION	Text	1		
SIZE1	Number	Integer		
SIZE2	Number	Integer		
SHAPE	Text	1		
MATERIAL	Text	3		
LINING	Text	3		
PIPELENGTH	Number	Single		
TOTALLENGTH	Number	Single		
YEARLAID	Text	4		
VIDEONUMBER	Text	5		
COMMENTS	Text	50		
PURPOSE	Text	1		
SEWERCATEGORY	Text	1		
PRECLEANING	Text	1		
WEATHER	Text	1		
LOCATIONCODE	Text	1		
FURTHERDETAILS	Text	48		

CONDITION DETAILS TABLE

FIELD NAME	DATA TYPE	FIELD PROPERTIES	CITY OF..... FIELD NAME
ID	AutoNumber	Long integer	
VIDEONUMBER	Date/Time	hh:nn:ss	
PHOTOGRAPHNUMBER	Number	Integer	
DISTANCE	Number	Single	
CONTINUOUSDEFECT	Text	2	
CODE	Text	4	
DIAMETER_DIMENSION	Number	Integer	
CLOCKFROM	Number	Integer, "00"	
CLOCKTO	Number	Integer, "00"	
PERCENTAGE	Number	Byte	
INTRUSION	Number	Integer	
JOBNUMBER	Text	10	
REMARKS	Text	34	

*****END OF SECTION*****